

Tiffin Regular City Council Meeting

Tiffin Regular City Council Meeting

May 05, 2026 07:00 pm



May 5, 2026

7:00 PM

Regular Formal

City Council Meeting

Tiffin City Hall

300 Railroad Street, Tiffin, Iowa 52340

www.tiffin-iowa.org

Mayor:	Tim Kasparek	Public Works Director:	Brian Detert
Council At Large:	Tim Orris – Mayor Pro-Tem	Water/WW Superintendent:	Brett Mehmen
Council At Large:	Tony Johnson	Building Official:	Brian Shay
Council At Large:	Skylar Limkemann	Recreation Director:	Grant Weber
Council At Large:	Chris Olney	Library Director:	Liz Petersen Grier
Council At Large:	Eric Schnedler	Fire Chief:	VACANT
City Administrator:	Doug Boldt	City Engineer:	MSA Professional Services
Asst. City Admin.	Ashley Platz		
City Attorney	Crystal Raiber		
City Clerk	Abigail Hora		

A. **Call to Order - 7:00PM**

File: [5-5-26 Agenda](#)

B. **Roll Call**

C. **Agenda Additions/Agenda Approval**

Note: These are routine items and will be enacted by one motion without separate discussion unless a Council Member requests separate consideration.

D. Communications and Reports

1. County Elected Officials Presentation - County Attorney, Treasurer, Auditor and Sheriff

2. Unscheduled

This is an opportunity for those wishing to address the City Council on an item NOT on the agenda. If you wish to address the Council on subjects pertaining to today's meeting agenda, please wait until that item on the agenda is reached.

If you wish to speak now, please approach the lectern and give your name and address for the public record before discussing your item.

As a reminder each speaker is limited to 3 minutes or less.

As an additional reminder, in accordance with public meeting laws, the Council may only discuss or act on matters that are presented on this agenda.

E. Consent Agenda

Note: These are routine items and will be enacted by one motion without separate discussion unless a Council Member requests separate consideration.

1. Approval of April 21, 2026 Council Minutes

File: [E.1](#)

2. Approval of Summary of Receipts Report

File: [E.2](#)

F. Mayoral Proclamation

1. Older Americans Month 2026

File: [F.1](#)

2. 57th Annual Professional Municipal Clerks Week

File: [F.2](#)

G. Public Hearing

H. Ordinance Approval/Amendment

1. Ordinance No. 2026-525 – An Ordinance Amending the Official Zoning Map of the City of Tiffin, Iowa, to Rezone Andersen Addition – Part Three,

Ordinance No. 2026-525 – An Ordinance Amending the Official Zoning Map of the City of Tiffin, Iowa, to Rezone Andersen Addition – Part Three, from R-12/OPD Concept District to R-1D/OPD Site and Concept District for Lotus Hill North, in the City of Tiffin, Iowa, Johnson County, Iowa

- a. Motion to Approve Second Reading and Proceed to Third Reading

File: [H.1](#)

2. Ordinance No. 2026-526 – An Ordinance Amending the Official Zoning Map of the City of Tiffin, Iowa, to Rezone Andersen Addition – Part Three,

Ordinance No. 2026-526 – An Ordinance Amending the Official Zoning Map of the City of Tiffin, Iowa, to Rezone Andersen Addition – Part Three, from R-12/OPD Concept District to R-1C, in the City of Tiffin, Iowa, Johnson County, Iowa

- a. Motion to Approve Second Reading and Proceed to Third Reading

File: [H.2](#)

3. Ordinance No. 2026-527 – An Ordinance Amending the Official Zoning Map of the City of Tiffin, Iowa, to Rezone Lots 56, 57 and 58 of Tiffin Heights West

Ordinance No. 2026-527 – An Ordinance Amending the Official Zoning Map of the City of Tiffin, Iowa, to Rezone Lots 56, 57 and 58 of Tiffin Heights West from C-2B (Community Business District) to P-1 (Public Use), in the City of Tiffin, Iowa, Johnson County, Iowa

- a. Motion to Approve First Reading and Proceed to Second Reading

File: [H.3](#)

I. Resolutions for Approval

1. Resolution No. 2026-028 – A Resolution Setting the Date of May 19, 2026, for a Public Hearing on the FY 2025-2026 Budget Amendment

File: [I.1](#)

2. Resolution No. 2026-029 – A Resolution Certifying the 2025 Special Federal Census for the City of Tiffin to the Iowa Secretary of State and the Treasurer of the State of Iowa

File: [I.2](#)

3. Resolution No. 2026-030 – A Resolution to Update the Petty Cash/Change Fund and Policies on Use Thereof

File: [I.3](#)

4. Resolution No. 2026-031 – A Resolution to Approve Modifications to the OPD Building Renderings for Lotus Hill South, Tiffin, Iowa

File: [I.4](#)

5. Resolution No. 2026-032 - A Resolution Approving the Amended Preliminary Plat of Andersen Addition – Part Three

File: [I.5](#)

6. Resolution No. 2026-033 - A Resolution Approving the Third Amendment to the Andersen Addition Subdividers Agreement

File: [I.6](#)

J. Old Business

K. Motions for Approval

1. **Consideration of Payables List - Motion to Approve**
File: [K.1](#)
2. **Discussion and Consideration of Pay Application #8 – Tricon Construction – Tiffin Water Treatment Facility Upgrade Project – Motion to Approve**
File: [K.2](#)
3. **Discussion and Consideration of Approval of State Revolving Fund (SRF) Reimbursement Request #4 – Water Treatment Facility Upgrade Project – Motion to Approve**
File: [K.3](#)
4. **Discussion and Consideration of Change Order #15 – Boomerang Corporation – North Park Road Improvements Project – Motion to Approve**
File: [K.4](#)
5. **Discussion and Consideration of Pay Application #12– Boomerang Corporation, North Park Road Improvements Project – Motion to Approve**
File: [K.5](#)
6. **Discussion and Consideration of Mayoral Proclamation Request Policy and Council Action as Needed**
File: [K.6](#)
7. **Discussion and Consideration of Interim Fire Chief and Council Action as Needed**

L. Reports to be Received/Filed

1. **City Engineer Report**
File: [L.1](#)

M. Reports from City Personnel

1. Mayor's Report
2. City Council Reports
3. Director of Public Work's Report
4. Building Official's Report - **Review of City Code Chapter 52 - Weeds & Noxious Growths**
5. Water/Wastewater Superintendent's Report
6. Recreation Director's Report
7. Fire Chief's Report
8. Law Enforcement Report
9. City Attorney's Report
10. City Administrator's Report - **Included in Packet**

File: [M.10](#)

File: [M.4 - Flowchart](#)

N. Adjournment

Pursuant to §21.4(2) of the Code of Iowa, the City has the right to amend this agenda up until 24 hours before the posted meeting time.

If anyone with a disability would like to attend the meeting, please call City Hall at 319-545-2572 to arrange for accommodations/transportation.

City of Tiffin, Iowa

Meeting: Tiffin City Council Meeting
Place: Tiffin City Hall 300 Railroad St, Tiffin, Iowa, 52340
Date/Time: May 5, 2026 – 7:00 p.m.
Web Page: www.tiffin-iowa.org
Posted: May 1, 2026 (website & front entry of City Hall)

Mayor:	Tim Kasparek	W/WW Superintendent:	Brett Mehmen
Council At Large:	Tim Orris – Mayor Pro-Tem	D. of Public Works:	Brian Detert
Council At Large:	Tony Johnson	Recreation Director:	Grant Weber
Council At Large:	Skylar Limkemann	Building Official:	Brian Shay
Council At Large:	Chris Olney	Library Director:	Liz Petersen Grier
Council At Large:	Eric Schnedler	Fire Chief:	Vacant
City Administrator:	Doug Boldt	City Engineer:	MSA Professional Services
Asst. City Administrator:	Ashley Platz		
City Clerk:	Abigail Hora		
City Attorney:	Crystal Raiber		

A. Call to Order – 7:00 PM

B. Roll Call

C. Agenda Additions/Agenda Approval

D. Communications and Reports

1. County Elected Officials Presentation – County Attorney, Treasurer, Auditor and Sheriff
2. Unscheduled

This is an opportunity for those wishing to address the City Council on an item NOT on the agenda. If you wish to address the Council on subjects pertaining to today's meeting agenda, please wait until that item on the agenda is reached.

If you wish to speak now, please approach the lectern and give your name and address for the public record before discussing your item. As a reminder each speaker is limited to 3 minutes or less. As an additional reminder, in accordance with public meeting laws, the Council may only discuss or act on matters that are presented on this agenda.

E. Consent Agenda

Note: These are routine items and will be enacted by one motion without separate discussion unless a Council Member requests separate consideration.

1. Approval of April 21, 2026, City Council Minutes
2. Approval of Summary of Receipts Report

F. Mayoral Proclamation

1. Older Americans Month 2026
2. 57th Annual Professional Municipal Clerks Week

G. Public Hearing

- 1.

H. Ordinance Approval/Amendment

1. Ordinance No. 2026-525 – An Ordinance Amending the Official Zoning Map of the City of Tiffin, Iowa, to Rezone Andersen Addition – Part Three, from R-12/OPD Concept District to R-1D/OPD Site and Concept District for Lotus Hill North, in the City of Tiffin, Iowa, Johnson County, Iowa
 - a. Motion to Approve Third and Final Reading
2. Ordinance No. 2026-526 – An Ordinance Amending the Official Zoning Map of the City of Tiffin, Iowa, to Rezone Andersen Addition – Part Three, from R-12/OPD Concept District to R-1C, in the City of Tiffin, Iowa, Johnson County, Iowa
 - a. Motion to Approve Third and Final Reading
3. Ordinance No. 2026-527 – An Ordinance Amending the Official Zoning Map of the City of Tiffin, Iowa, to Rezone Lots 56, 57 and 58 of Tiffin Heights West from C-2B (Community Business District) to P-1 (Public Use), in the City of Tiffin, Iowa, Johnson County, Iowa
 - a. Motion to Approve Second Reading and Proceed to Third Reading

I. Resolutions for Approval

1. Resolution No. 2026-028 – A Resolution Setting the Date of May 19, 2026, for a Public Hearing on the FY 2025-2026 Budget Amendment

2. Resolution No. 2026-029 – A Resolution Certifying the 2025 Special Federal Census for the City of Tiffin to the Iowa Secretary of State and the Treasurer of the State of Iowa
3. Resolution No. 2026-030 – A Resolution to Update the Petty Cash/Change Fund and Policies on Use Thereof
4. Resolution No. 2026-031 – A Resolution to Approve Modifications to the OPD Building Renderings for Lotus Hill South, Tiffin, Iowa
5. Resolution No. 2026-032 – A Resolution Approving the Amended Preliminary Plat of Andersen Addition – Part Three
6. Resolution No. 2026-033 – A Resolution Approving the Third Amendment to the Andersen Addition Subdividers Agreement

J. Old Business

- 1.

K. Motions for Approval

1. Consideration of Payables List – Motion to Approve
2. Discussion and Consideration of Pay Application #8 – Tricon Construction – Tiffin Water Treatment Facility Upgrade Project – Motion to Approve
3. Discussion and Consideration of Approval of State Revolving Fund (SRF) Reimbursement Request #4 – Water Treatment Facility Upgrade Project – Motion to Approve
4. Discussion and Consideration of Change Order #15 – Boomerang Corporation – North Park Road Improvements Project – Motion to Approve
5. Discussion and Consideration of Pay Application #12– Boomerang Corporation, North Park Road Improvements Project – Motion to Approve
6. Discussion and Consideration of Mayoral Proclamation Request Policy and Council Action as Needed
7. Discussion and Consideration of Interim Fire Chief and Council Action as Needed

L. Reports to be Received/Filed

1. City Engineer’s Report

M. Reports from City Personnel

1. Mayor’s Report
2. City Council Reports
3. Director of Public Work’s Report
4. Building Official’s Report – Review of City Code Chapter 52 – Weeds and Noxious Growths
5. Water/Wastewater Superintendent’s Report
6. Recreation Director’s Report
7. Fire Department Report
8. Law Enforcement Report
9. City Attorney’s Report
10. City Administrator’s Report – Included in Packet

N. Adjournment

Pursuant to §21.4(2) of the Code of Iowa, the City has the right to amend this agenda up until 24 hours before the posted meeting time.

If anyone with a disability would like to attend the meeting, please call City Hall at 319-545-2572 to arrange for accommodations/transportation.

City of Tiffin, Iowa

Meeting:	Tiffin City Council Meeting
Place:	Tiffin City Hall 300 Railroad St, Tiffin, Iowa, 52340
Date/Time:	April 21, 2026 – 7:00 p.m.
Web Page:	www.tiffin-iowa.org
Posted:	April 17, 2026 (website & front entry of City Hall)

Mayor:	Tim Kasparek	W/WW Superintendent:	Brett Mehmen
Council At Large:	Tim Orris – Mayor Pro-Tem	D. of Public Works:	Brian Detert
Council At Large:	Tony Johnson	Recreation Director:	Grant Weber
Council At Large:	Skylar Limkemann	Building Official:	Brian Shay
Council At Large:	Chris Olney	Library Director:	Liz Petersen Grier
Council At Large:	Eric Schnedler	Fire Chief:	Vacant
City Administrator:	Doug Boldt	City Engineer:	MSA Professional Services
Asst. City Administrator:	Ashley Platz		
City Clerk:	Abigail Hora		
City Attorney:	Crystal Raiber		

Work Session - Call to Order – 5:30 PM

A. Roll Call

The City of Tiffin City Council held a work session Tuesday, April 21, 2026, at the Tiffin City Hall Council Chambers. Mayor Kasparek (present via Microsoft Teams) called the meeting to order at 5:30 PM. Upon roll being called the following members were present: Eric Schnedler, Tony Johnson, Chris Olney, Tim Orris (present via Microsoft Teams) and Skylar Limkemann (present via Microsoft Teams). Others present were City Administrator Doug Boldt, Assistant City Administrator Ashley Platz and City Clerk Abigail Hora.

B. Agenda Additions/Agenda Approval

Motion to approve agenda by Olney.

Second by Johnson.

All ayes, agenda approved.

C. Review of Park Place City Center future Buildings and Master Plan

Discussion: Scott Andersen present to review the next proposed building in the Park Place City Center development, known as “The Pacific,” and to provide an update on the overall buildout of Park Place. Discussion was held regarding The Pacific and Marvin Gardens, which represent a shift from earlier buildings—such as New York, Ventnor, Baltic, and Boardwalk—as both are proposed to be entirely residential. The Master Plan and building elevations were provided for Council review. This item served as a brief discussion to give an overview of the project’s direction moving forward.

D. Discussion of Madden Addition Outlot B and the potential to convert it to a Buildable Lot

Discussion: Dan Sweeting attended and presented the possibility of allowing Outlot B in Madden Addition – Part Two (part of Lot 55 OPD) to be developed as a single buildable lot, with access from Ropp Way. Discussion was held regarding the attached preliminary plat and the language in the site agreement, which currently identify the outlot as open space to be privately owned and maintained by the homeowners’ association. Council was okay with this moving forward.

E. Discussion and Final Review of Highway 6 Reconstruction Project prior to Submittal to the IDOT

Discussion: James Watters with MSA attended via Microsoft Teams and provided the Council with a final review of the Highway 6 Reconstruction Project prior to its submission to IDOT next month. Discussion was held to confirm that all previously discussed items—such as sidewalks, a pedestrian beacon, turning lanes, and traffic signals—have been incorporated into the overall project scope and are reflected in its final form before submission to IDOT for review.

F. Discussion and Review of Potential Partnership with Greater Iowa City for Economic Development Services

Discussion: Nancy Bird, Cady Gerlach, Evan Doyle, and Tom Martinez from Greater Iowa City attended the meeting to discuss a potential partnership with the City for economic development services. Discussion was held regarding the draft agreement, and the Greater Iowa City team provided a PowerPoint presentation.

Greater Iowa City collaborates with several communities across Johnson County to support and promote economic growth. A potential partnership, including an expanded presence in Tiffin, was discussed as an opportunity to provide the City with an additional resource for advancing its economic development goals through established connections, lead generation, and regional collaboration.

G. Questions from Council Members regarding items on the Regular City Council Agenda or Reports

H. Other Business

I. Adjournment

Motion to adjourn by Schnedler.

Second by Johnson.

All ayes, meeting adjourned at 7:04 PM.

A. Regular Session - Call to Order – 7:00 PM

B. Roll Call

The City of Tiffin City Council held a regular session Tuesday, April 21, 2026, at the Tiffin City Hall Council Chambers. Mayor Kasperek (present via Microsoft Teams) called the meeting to order at 7:05 PM. Upon roll being called the following members were present: Eric Schnedler, Tony Johnson, Chris Olney, Tim Orris left at 7:35 PM (present via Microsoft Teams) and Skylar Limkemann left at 7:09 PM (present via Microsoft Teams). Others present were City Administrator Doug Boldt, Assistant City Administrator Ashley Platz and City Clerk Abigail Hora.

C. Agenda Additions/Agenda Approval

Motion to approve agenda by Johnson.

Second by Orris.

All ayes, agenda approved.

D. Communications and Reports

1. Unscheduled

This is an opportunity for those wishing to address the City Council on an item NOT on the agenda. If you wish to address the Council on subjects pertaining to today's meeting agenda, please wait until that item on the agenda is reached.

If you wish to speak now, please approach the lectern and give your name and address for the public record before discussing your item. As a reminder each speaker is limited to 3 minutes or less. As an additional reminder, in accordance with public meeting laws, the Council may only discuss or act on matters that are presented on this agenda.

E. Consent Agenda

Note: These are routine items and will be enacted by one motion without separate discussion unless a Council Member requests separate consideration.

1. Approval of April 3, 2026, Special City Council Minutes

2. Approval of April 7, 2026, Special City Council Minutes

3. Approval of April 7, 2026, City Council Minutes

4. Approval of Summary of Receipts Report

5. Approval of Clerk's/Treasurers Report

Motion to approve Consent Agenda which includes Special City Council Minutes, Special City Council Minutes, City Council Minutes, Summary of Receipts Report and Clerk's/Treasurers Report by Orris.

Second by Johnson.

All ayes, consent agenda approved.

F. Mayoral Proclamation

1.

G. Public Hearing

1. Public Hearing on the FY 2026-2027 Proposed Budget

a. Close Public Hearing and Proceed to I-1

Motion to open Public Hearing on the FY 2026-2027 Proposed Budget by Orris.

Second by Johnson.

Roll Call: Orris, Olney, Johnson, Schnedler, Limkemann.

Discussion: Nothing Received at City Hall.

Motion to close Public Hearing on the FY 2026-2027 Proposed Budget by Schnedler.

Second by Olney.

Roll Call: Olney, Johnson, Schnedler, Limkemann, Orris.

All ayes, motion carried.

2. Public Hearing on Ordinance No. 2026-527 – An Ordinance Amending the Official Zoning Map of the City of Tiffin, Iowa, to Rezone Lots 56, 57 and 58 of Tiffin Heights West from C-2B (Community Business District) to P-1 (Public Use), in the City of Tiffin, Iowa, Johnson County, Iowa

- a. Close Public Hearing and Proceed to H-3

Motion to open Public Hearing on Ordinance No. 2026-527 – An Ordinance Amending the Official Zoning Map of the City of Tiffin, Iowa, to Rezone Lots 56, 57 and 58 of Tiffin Heights West from C-2B (Community Business District) to P-1 (Public Use), in the City of Tiffin, Iowa, Johnson County, Iowa by Olney.

Second by Orris.

Roll Call: Schnedler, Orris, Olney, Johnson.

Discussion: Nothing Received at City Hall.

Motion to close Public Hearing on Ordinance No. 2026-527 – An Ordinance Amending the Official Zoning Map of the City of Tiffin, Iowa, to Rezone Lots 56, 57 and 58 of Tiffin Heights West from C-2B (Community Business District) to P-1 (Public Use), in the City of Tiffin, Iowa, Johnson County, Iowa by Schnedler.

Second by Johnson.

Roll Call: Orris, Olney, Johnson, Schnedler.

All ayes, motion carried.

H. Ordinance Approval/Amendment

1. Ordinance No. 2026-525 – An Ordinance Amending the Official Zoning Map of the City of Tiffin, Iowa, to Rezone Andersen Addition – Part Three, from R-12/OPD Concept District to R-1D/OPD Site and Concept District for Lotus Hill North, in the City of Tiffin, Iowa, Johnson County, Iowa

- a. Motion to Approve Second Reading and Proceed to Third Reading

Motion to approve by Orris.

Second by Johnson.

Roll Call: Johnson, Schnedler, Orris, Olney.

All ayes, second reading approved.

2. Ordinance No. 2026-526 – An Ordinance Amending the Official Zoning Map of the City of Tiffin, Iowa, to Rezone Andersen Addition – Part Three, from R-12/OPD Concept District to R-1C, in the City of Tiffin, Iowa, Johnson County, Iowa

- a. Motion to Approve Second Reading and Proceed to Third Reading

Motion to approve by Johnson.

Second by Orris.

Roll Call: Olney, Johnson, Schnedler, Orris.

All ayes, second reading approved.

3. Ordinance No. 2026-527 – An Ordinance Amending the Official Zoning Map of the City of Tiffin, Iowa, to Rezone Lots 56, 57 and 58 of Tiffin Heights West from C-2B (Community Business District) to P-1 (Public Use), in the City of Tiffin, Iowa, Johnson County, Iowa

- a. Motion to Approve First Reading and Proceed to Second Reading

Motion to approve by Orris.

Second by Schnedler.

Roll Call: Orris, Olney, Johnson, Schnedler.

All ayes, first reading approved.

I. Resolutions for Approval

1. Resolution No. 2026-026 – A Resolution Approving the City of Tiffin Fiscal Year 2026-2027 Annual Budget. Motion to approve by Orris.
Second by Johnson.
Roll Call: Johnson, Schnedler, Orris, Olney.
All ayes, motion carried.
2. Resolution No. 2026-027 – A Resolution Setting the Date of May 19, 2026, for a Public Hearing on the Plans, Specifications, Form of Contract, Estimate of Costs and Authorizing Publication of Notices for the Village Drive and Roberts Ferry Road Traffic Signal Project and Opening of Bids on May 14, 2026. Motion to approve by Orris.
Second by Johnson.
Roll Call: Schnedler, Orris, Olney, Johnson.
All ayes, motion carried.

J. Old Business

- 1.

K. Motions for Approval

1. Consideration of Payables List – Motion to approve by Orris.
Second by Schnedler.
All ayes, motion carried.
2. Discussion and Consideration of Pay Application #10 – Miron Construction – Tiffin Recreation Center Project – Motion to approve by Orris.
Second by Johnson.
All ayes, motion carried.
3. Discussion and Consideration of Pay Application #11 – Miron Construction – Tiffin Recreation Center Project – Motion to approve by Olney.
Second by Orris.
All ayes, motion carried.

L. Reports to be Received/Filed

1. March Johnson County Sheriff's Report
2. Monthly Departmental Budget Reports
3. Tiffin Recreation Center Monthly Report

M. Reports from City Personnel

1. Mayor's Report – Nothing to Report.
2. City Council Reports – Discussion: Council Person Schnedler raised concerns about parking over the sidewalk in some areas of the city.
3. Director of Public Work's Report – Nothing to Report.
4. Building Official's Report – Nothing to Report.
5. Water/Wastewater Superintendent's Report - Nothing to Report.
6. Recreation Director's Report - Nothing to Report.
7. Fire Department Report - Nothing to Report.
8. Law Enforcement Report - Nothing to Report.
9. City Attorney's Report – Nothing to Report.
10. City Administrator's Report – Included in Packet. Village Drive will be signed 25 mph.

N. Adjournment

Motion to adjourn by Schnedler.
Second by Olney.
All ayes, meeting adjourned at 7:46 PM.

Abigail Hora

____ April 23rd, 2026
Abigail Hora, City Clerk

City of Tiffin Summary of Receipts

04/17/2026-04/30/2026

001-GENERAL	\$	49,753.66
110-ROAD USE TAX	\$	51,876.41
112-EMPLOYEE BENEFIT	\$	-
119-EMERGENCY FUND	\$	-
121-LOCAL OPTION SALES TAX	\$	91,290.89
125-TIF	\$	-
200-DEBT SERVICE	\$	-
301-DEVELOPER ESCROW	\$	-
307-PARK ROAD PAVING	\$	-
309-US HWY 6 RECONSTRUCTION	\$	-
310-TRAIL PROJECT	\$	-
316-GO BONDS	\$	38,993.60
320-ROUNDABOUT	\$	-
321-ORIGINAL TOWN URBANIZATION	\$	-
335-FOREVERGREEN RD	\$	-
336-PUBLIC WORKS BUILDING	\$	-
340-RECREATION CENTER	\$	-
344-PW EQUIPMENT	\$	-
600-WATER	\$	81,141.02
601-WATER SINKING	\$	-
607-SECOND WELL	\$	-
608-WATER TREATMENT PLANT	\$	-
610-SEWER	\$	74,241.86
611-SEWER SINKING	\$	-
617-SANITARY SEWER IMPROVEMENTS	\$	-
618-SEWER MAIN UPSIZE RAILROAD	\$	-
670-RECYCLING/GARBAGE	\$	29,668.77
740-STORM WATER	\$	6,531.34
TOTAL:	\$	423,497.55



300 Railroad St. PO Box 259 Tiffin, IA 52340
P. 319-545-2572 F. 319-545-4147 www.tiffin-iowa.org

**PROCLAMATION
BY THE MAYOR OF THE CITY OF TIFFIN**

Older Americans Month 2026

WHEREAS, *Johnson County Livable Community for Successful Aging (JCLC)* seeks to collaboratively celebrate the lives and benefits of older adults in the communities throughout this County; and,

WHEREAS, May is Older Americans Month, a time for us to recognize and honor the older adults of Tiffin and their influence on every facet of American society; and,

WHEREAS, older Americans improve our communities through intergenerational relationships, community service, civic engagement, and many other activities; and,

WHEREAS, the Older Americans 2026 theme, is Champion Your Health, focuses on prevention, wellness, and personal responsibility as cornerstones of healthy aging. It encourages taking an active role in managing your own health, advocating for yourself, accessing preventive care, and making informed decisions that support independence. Join us in highlighting the importance of evidence-based approaches, self-management, and community partnerships that empower individuals to lead their healthiest lives; and,

WHEREAS, the City of Tiffin must ensure that older Americans have the resources and support needed to stay involved in their communities — reflecting our commitment to inclusivity and connectedness; and,

NOW, THEREFORE, I, Tim Kasperek, Mayor of the City of Tiffin, do hereby proclaim the month of:

May 2026 as Older Americans Month

in the City of Tiffin and urge all citizens to celebrate the profound positive impact of meaningful interactions and social connections with seniors for the entire community.

IN TESTIMONY WHEREOF, I have hereunto signed my name and have officially caused the Seal of the City to be affixed this 5th day of May, 2026.

Signed this 5th day of May, 2026, in Johnson County, Iowa.

City of Tiffin

Tim Kasperek, Mayor

ATTEST: _____
Abigail Hora, City Clerk



300 Railroad St. PO Box 259 Tiffin, IA 52340
P. 319-545-2572 F. 319-545-4147 www.tiffin-iowa.org

**PROCLAMATION
BY THE MAYOR OF THE CITY OF TIFFIN**

**57th ANNUAL PROFESSIONAL MUNICIPAL CLERKS WEEK
May 3 - 9, 2026**

WHEREAS, The Office of the Professional Municipal Clerk, a time honored and vital part of local government exists throughout the world; and,

WHEREAS, The Office of the Professional Municipal Clerk is the oldest among public servants; and,

WHEREAS, The Office of the Professional Municipal Clerk provides the professional link between the citizens, the local governing bodies and agencies of government at other levels; and,

WHEREAS, Professional Municipal Clerks have pledged to be ever mindful of their neutrality and impartiality, rendering equal service to all; and,

WHEREAS, The Professional Municipal Clerk serves as the information center on functions of local government and community; and,

WHEREAS, Professional Municipal Clerks continually strive to improve the administration of the affairs of the Office of the Professional Municipal Clerk through participation in education programs, seminars, workshops and the annual meetings of their state, provincial, county and international professional organizations.

WHEREAS, It is most appropriate that we recognize the accomplishments of the Office of the Professional Municipal Clerk.

NOW, THEREFORE, I, Tim Kasperek, Mayor of the City of Tiffin, recognize the week of

**May 3 through May 9, 2026, as
Professional Municipal Clerks Week,**

and further extend appreciation to our Professional Municipal Clerks in City Hall and to all Professional Municipal Clerks for the vital services they perform and their exemplary dedication to the communities they represent.

IN TESTIMONY WHEREOF, I have hereunto signed my name and have officially caused the Seal of the City to be affixed this 5th day of May, 2026.

Signed this 5th day of May, 2026, in Johnson County, Iowa.

City of Tiffin

Tim Kasperek, Mayor

ATTEST: _____
Abigail Hora, City Clerk

CITY OF TIFFIN ORDINANCE NO. 2026-525

AN ORDINANCE AMENDING THE OFFICIAL ZONING MAP OF THE CITY OF TIFFIN, IOWA, TO REZONE ANDERSEN ADDITION - PART THREE, FROM R-12/OPD CONCEPT DISTRICT TO R-1D/OPD SITE AND CONCEPT DISTRICT FOR LOTUS HILL NORTH, IN THE CITY OF TIFFIN, IOWA, JOHNSON COUNTY, IOWA, AND AS LEGALLY DESCRIBED HEREIN

BE IT ENACTED BY THE CITY COUNCIL OF TIFFIN, IOWA:

Section 1. Purpose. The purpose of this ordinance is to amend the official zoning map of the City of Tiffin, Iowa, concerning Andersen Addition Part Three – Lotus Hill North, Tiffin, Johnson County, Iowa, attached hereto and incorporated herein.

Section 2. Amendment. The following legally described property:

DESCRIPTION - PROPOSED OPD-LOTUS HILL NORTH ZONING

COMMENCING at the Northeast Corner of said Southwest Quarter of the Northwest Quarter of Section 22, Township 80 North, Range 7 West, of the Fifth Principal Meridian, Tiffin, Johnson County, Iowa; Thence S00°50'43"E, along the East Line of said Southwest Quarter of the Northwest Quarter, 644.93 feet, TO THE POINT OF BEGINNING; Thence continuing S00°50'43"E, along said East Line, 158.00 feet; Thence S89°29'44"W, 1066.64 feet; Thence Northwesterly, 90.89 feet, along a 300.00 foot radius curve, concave Northeasterly, whose 90.54 foot chord bears N81°49'32"W; Thence N73°08'48"W, 139.96 feet; Thence Northwesterly, 61.48 feet, along a 300.00 foot radius curve, concave Northeasterly, whose 61.37 foot chord bears N67°16'34"W; Thence N61°24'20"W, 12.10 feet. to a Point on the East Line of Andersen Addition - Part Two, in accordance with the Plat thereof Recorded in Plat Book 66 at Page 62 of the Records of the Johnson County Recorder's Office; Thence Northeasterly, 75.78 feet. along said East Line, on a 960.00 foot radius curve, concave Southeasterly, whose 75.76 foot chord bears N30°51'22"E; Thence N33°07'03"E, along said East Line, and the Northeasterly Projection thereof, 134.23 feet; Thence S56°52'57"E, 109.95 feet; Thence S70°13'15"E, 124.30 feet; Thence N89°29'44"E, 1033.18 feet, to the POINT OF BEGINNING. Said OPD-Lotus Hill North Zoning Parcel contains 4.96 Acres, and is subject to easements and restrictions of record.

shall be changed from zoning classification R-12/OPD (Multi-Family, 9 thru 12 plex OPD) to R-1D/OPD (Single-Family/OPD) Site and Concept District in Tiffin, Iowa, and that the official zoning map of the City be amended to reflect the change described herein. Approval of this zoning classification change is subject to Council approval of a Developer's Agreement as required by the City, Planned Development Overlay District

Agreement(s) as required by the City and compliance with the requirements of the Tiffin Zoning Code - Planned Development Overlay District, and the Developer executing all easement agreements the City may require.

Section 3. Repealer. All ordinances or parts of ordinances in conflict with the provisions of this Ordinance are hereby repealed.

Section 4. Severability. If any section, provision, or part of this ordinance shall be adjudged to be invalid or unconstitutional, such adjudication shall not affect the validity of the ordinance as a whole, or any section, provision, or part thereof not adjudged invalid or unconstitutional.

Section 5. Effective Date. This ordinance shall be in effect after its final passage, approval, and posting as provided by law.

On the 7th day of April, 2026, at a regular meeting of the Tiffin City Council, Tiffin, Iowa, Councilperson Johnson introduced Ordinance No. 2026-525, and moved that it be given its first reading. The motion was seconded by Councilperson Schnedler.

Ayes: Johnson, Schnedler, Limkemann, Orris, Olney.

Nays: None.

Five members of the Council being present and having voted "Aye", Mayor Tim Kasparek declared the motion carried, and Ordinance No. 2026-525, was read the first time, discussed, and placed on record.

On the 21st day of April, 2026, at a regular meeting of the Tiffin City Council, Tiffin, Iowa, Councilperson Orris introduced Ordinance No. 2026-525, and moved that it be given its second reading. The motion was seconded by Councilperson Johnson.

Ayes: Johnson, Schnedler, Orris, Olney.

Nays: None.

Four members of the Council being present and having voted "Aye", Mayor Tim Kasparek declared the motion carried, and Ordinance No. 2026-525, was read the second time and discussed and placed on record.

On the 5^{rh} day of May, 2026, at a regular meeting of the Tiffin City Council, Tiffin, Iowa, Councilperson ____ introduced Ordinance No. 2026-525, and moved that it be given its third and last reading. The motion was seconded by Councilperson ____.

Ayes:

Nays:

_____ members of the Council being present and having voted "Aye", Mayor Tim Kasperek declared the motion carried, and the ordinance was passed and adopted.

Whereupon the Mayor declared that Ordinance No. 2026-525 be adopted and signified his approval of same by fixing his signature thereto. Passed by the Council on the _____th day of _____, 2026, and approved by the Mayor on the _____th day of _____, 2026.

CITY OF TIFFIN, IOWA:

By: _____
Tim Kasperek, Mayor

ATTEST:

Abigail Hora, City Clerk

I, Abigail Hora, City Clerk of the City of Tiffin, Iowa, state that an ordinance entitled AN ORDINANCE AMENDING THE OFFICIAL ZONING MAP OF THE CITY OF TIFFIN, IOWA, TO REZONE ANDERSEN ADDITION - PART THREE, FROM R-12/OPD CONCEPT DISTRICT TO R-1D/OPD SITE AND CONCEPT DISTRICT FOR LOTUS HILL NORTH, IN THE CITY OF TIFFIN, IOWA, JOHNSON COUNTY, IOWA, AND AS LEGALLY DESCRIBED HEREIN, and known as Ordinance No. 2026-525 was duly passed by the Council on the _____th day of _____ 2026, and signed by the Mayor on the _____th day of _____ 2026, and published on the _____th day of _____ 2026, by posting copies thereof in three public places within the limits of the City of Tiffin, Iowa. That I posted copies of Ordinance No. 2026-525 in the following places:

The Depot, Tiffin, Iowa
Tiffin City Hall, Tiffin, Iowa
Solon State Bank, Tiffin, Iowa

Abigail Hora, City Clerk

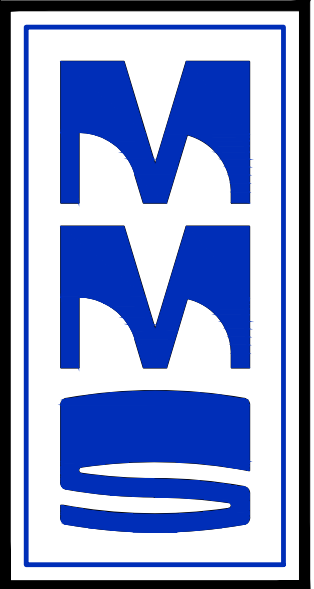

CIVIL ENGINEERS
LAND PLANNERS
LAND SURVEYORS
LANDSCAPE ARCHITECTS
ENVIRONMENTAL SPECIALISTS

1917 S. GILBERT ST.
IOWA CITY, IOWA 52240
(319) 351-8282
www.mmsconsultants.net

REZONING EXHIBIT

TIFFIN, JOHNSON COUNTY, IOWA

LEGEND AND NOTES	
	CONGRESSIONAL CORNER, FOUND
	PROPERTY CORNER(S), FOUND (as noted)
	PROPERTY CORNERS SET (5/8" Iron Pin w/ yellow, plastic LS Cap embossed with "MMS")
	CUT "X"
	PROPERTY &/or BOUNDARY LINES
	CONGRESSIONAL SECTION LINES
	RIGHT-OF-WAY LINES
	CENTER LINES
	LOT LINES, INTERNAL
	LOT LINES, PLATTED OR BY DEED
	EASEMENT LINES, WIDTH & PURPOSE NOTED
	EXISTING EASEMENT LINES, PURPOSE NOTED
	RECORDED DIMENSIONS
	MEASURED DIMENSIONS
	CURVE SEGMENT NUMBER

UNLESS NOTED OTHERWISE, ALL DIMENSIONS ARE IN FEET AND HUNDRETHS

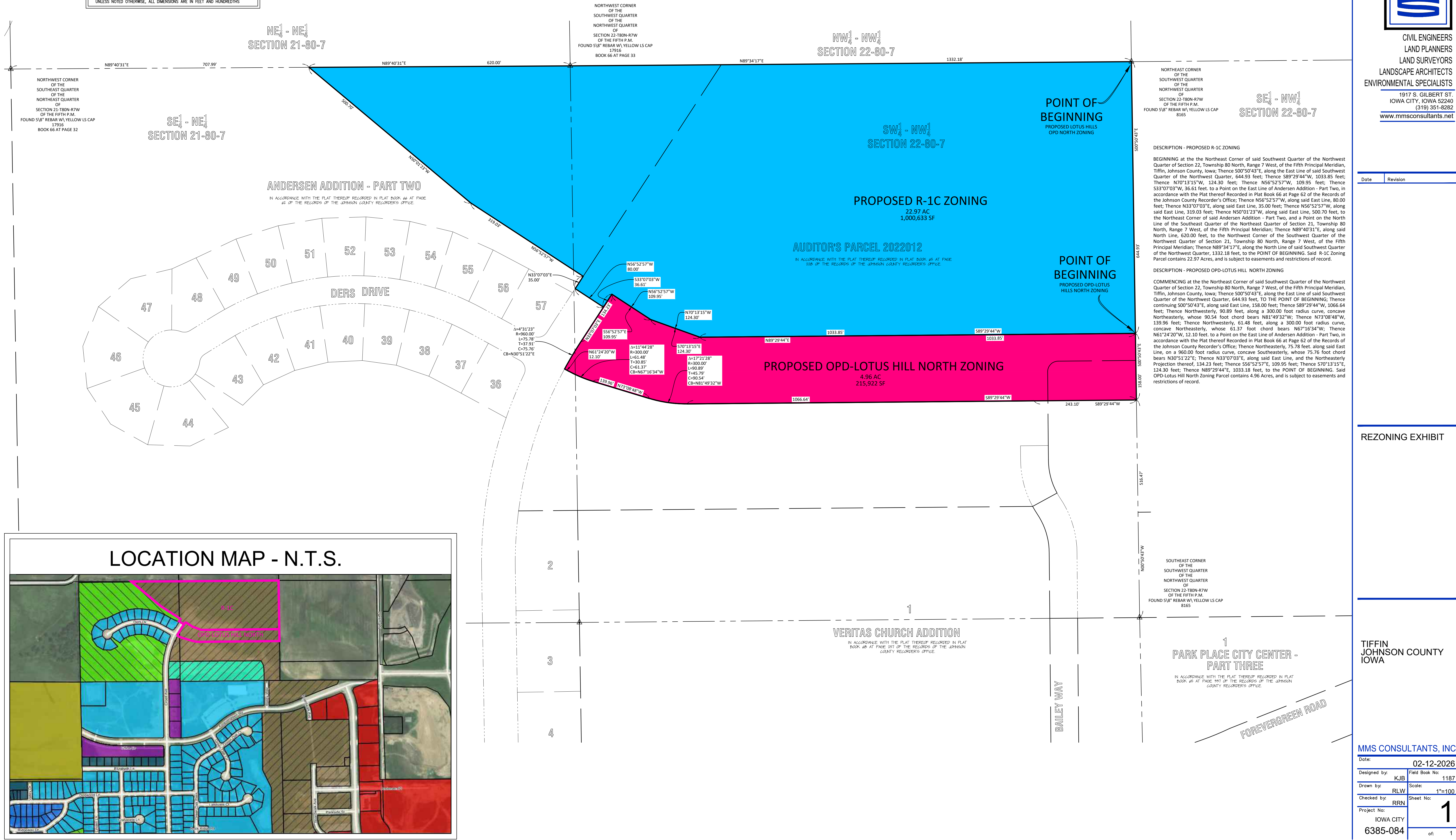
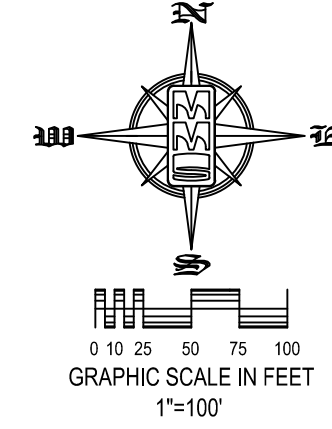

Date	Revision

REZONING EXHIBIT

TIFFIN
JOHNSON COUNTY
IOWA

MMS CONSULTANTS, INC.	
Date:	02-12-2026
Designed by:	KJB
Drawn by:	RLW
Checked by:	RRN
Project No:	IOWA CITY 6385-084
Field Book No:	1187
Scale:	1"=100'
Sheet No:	1
of:	1

SITE OPD EXHIBIT LOTUS HILL NORTH TIFFIN, IOWA

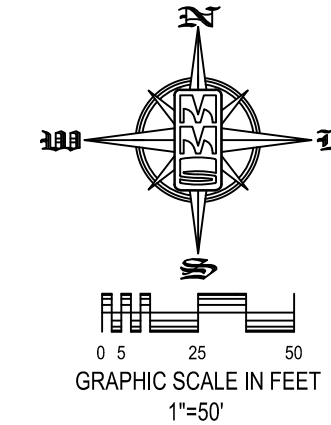

LEGAL DESCRIPTION - LOTUS HILL NORTH

LOT 27 THRU 56 AND OUTLOTS "B" AND "C", ANDERSEN ADDITION - PART THREE, TIFFIN, IOWA IN ACCORDANCE WITH THE PLAT THEREOF RECORDED IN THE RECORDS OF THE JOHNSON COUNTY RECORDER'S OFFICE, CONTAINING 3.92 ACRES, AND SUBJECT TO EASEMENTS AND RESTRICTIONS OF RECORD.

DEVELOPMENT CHARACTERISTICS
PROPOSED ZONING: OPD-LOTUS HILL NORTH

SETBACK MINIMUMS:
BUILDING SETBACKS: REQUIRED
FRONT YARD: 20 FEET
SIDE YARD: 5 FEET
CORNER YARD: 15 FEET
REAR YARD: 20 FEET

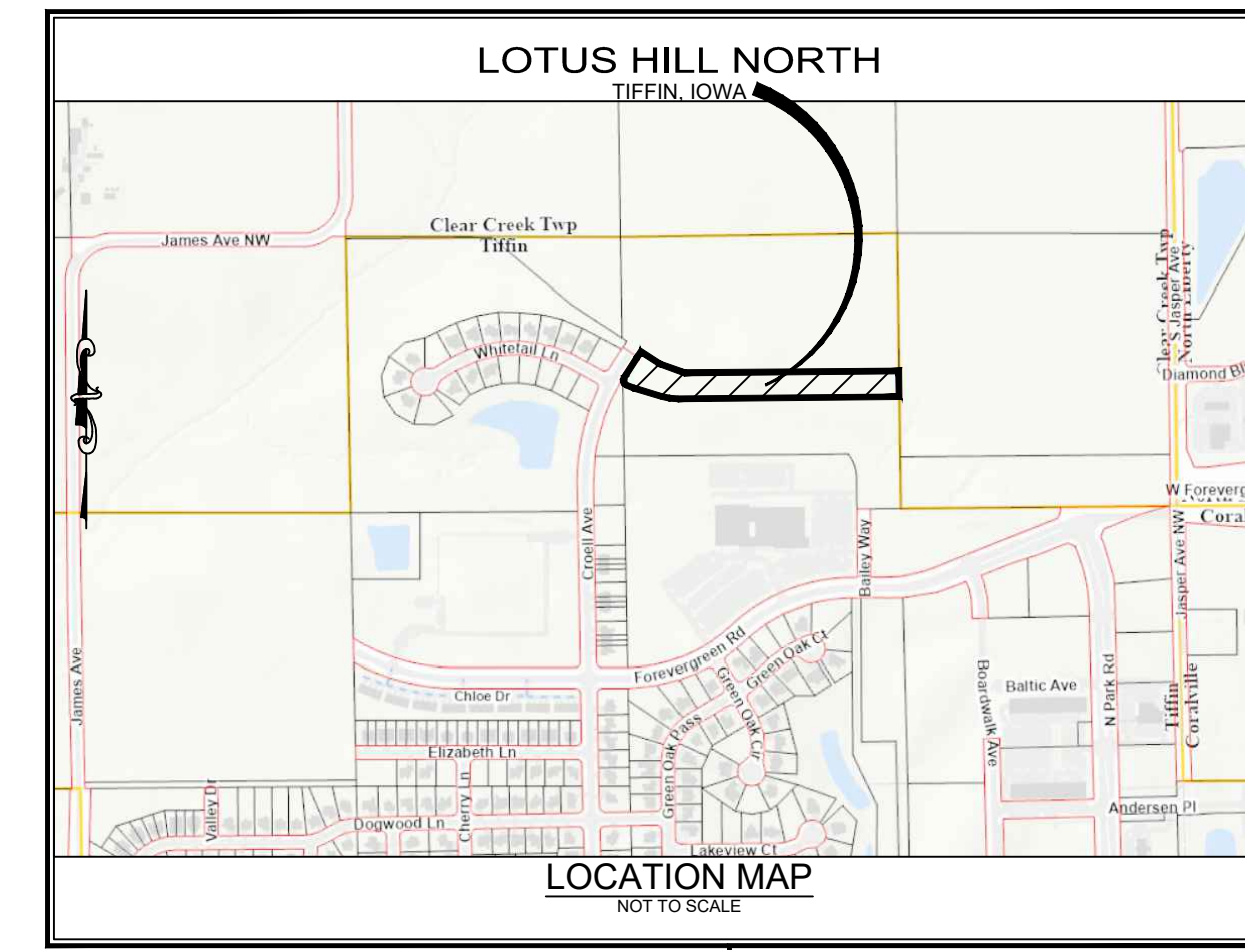
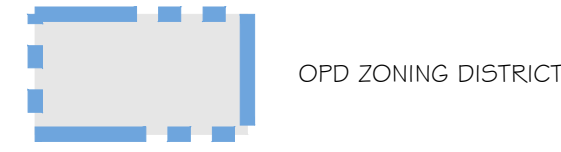

STANDARD LEGEND AND NOTES

- PROPERTY &/or BOUNDARY LINES
 - CONGRESSIONAL SECTION LINES
 - RIGHT-OF-WAY LINES
 - EXISTING RIGHT-OF-WAY LINES
 - CENTER LINES
 - EXISTING CENTER LINES
 - LOT LINES, INTERNAL
 - LOT LINES, PLATTED OR BY DEED
 - PROPOSED EASEMENT LINES
 - EXISTING EASEMENT LINES
 - BENCHMARK
 - RECORDED DIMENSIONS
 - CURVE SEGMENT NUMBER
-
- EXIST- POWER POLE
 - EXIST- POWER POLE W/DROP
 - EXIST- POWER POLE W/TRANS
 - EXIST- POWER POLE W/LIGHT
 - EXIST- GUY POLE
 - EXIST- LIGHT POLE
 - EXIST- SANITARY MANHOLE
 - EXIST- FIRE HYDRANT
 - EXIST- WATER VALVE
 - EXIST- DRAINAGE MANHOLE
 - EXIST- CURB INLET
 - EXIST- FENCE LINE
 - EXIST- EXISTING SANITARY SEWER
 - EXIST- PROPOSED SANITARY SEWER
 - EXIST- EXISTING STORM SEWER
 - EXIST- PROPOSED STORM SEWER
 - EXIST- WATER LINES
 - EXIST- ELECTRICAL LINES
 - EXIST- TELEPHONE LINES
 - EXIST- GAS LINES
 - EXIST- CONTOUR LINES (1' INTERVAL)
 - EXIST- PROPOSED GROUND
 - EXIST- EXISTING GROUND
 - EXIST- EXISTING TREE LINE
 - EXIST- EXISTING DECIDUOUS TREE & SHRUB
 - EXIST- EXISTING EVERGREEN TREES & SHRUBS

PLAT/PLAN APPROVED
by the
City of Tiffin

Mayer: _____ Date: _____

UTILITY EASEMENTS, AS SHOWN HEREON, MAY OR MAY NOT, INCLUDE SANITARY SEWER LINES, AND/OR STORM SEWER LINES, AND/OR WATER LINES - SEE CONSTRUCTION PLANS FOR DETAILS.

THE ACTUAL SIZE AND LOCATION OF ALL PROPOSED FACILITIES SHALL BE VERIFIED WITH CONSTRUCTION DOCUMENTS, WHICH ARE TO BE PREPARED AND SUBMITTED SUBSEQUENT TO THE APPROVAL OF THIS DOCUMENT.



CIVIL ENGINEERS
LAND PLANNERS
LAND SURVEYORS
LANDSCAPE ARCHITECTS
ENVIRONMENTAL SPECIALISTS

1917 S. GILBERT ST.
IOWA CITY, IOWA 52240
(319) 351-8282
www.mmsconsultants.net

Date	Revision
03-13-25	PER STREET WIDTH CHANGE TAVIRAN

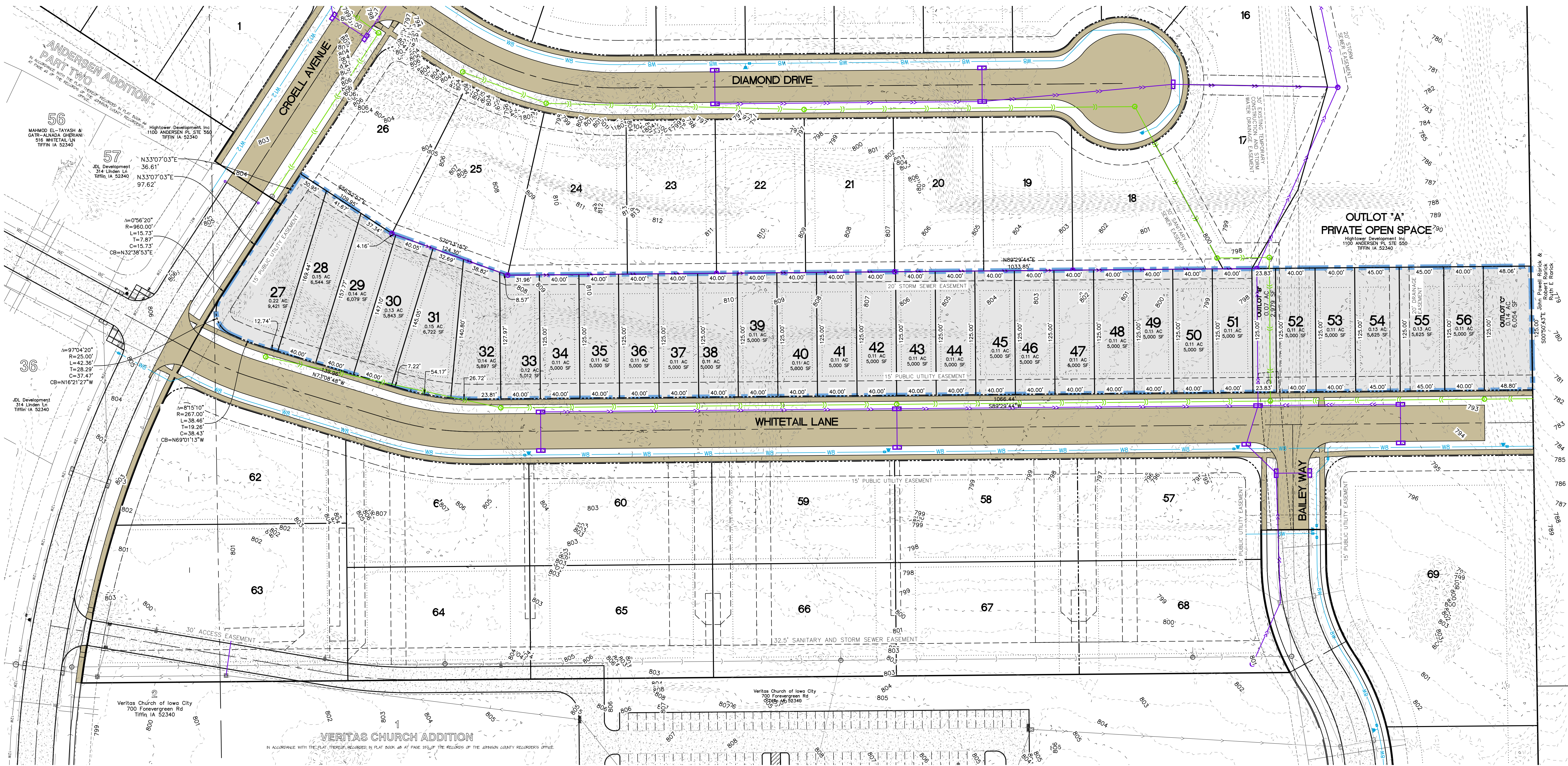

SITE OPD EXHIBIT LOTUS HILL NORTH

ANDERSEN
ADDITION -
PART THREE
TIFFIN
JOHNSON COUNTY,
IOWA

MMS CONSULTANTS, INC.

Date:	02-16-26
Designed by:	KJB Field Book No:
Drawn by:	TAV Scale: 1"=50'
Checked by:	RAN Sheet No: 1
Project No:	6385-084 of 1

CITY OF TIFFIN ORDINANCE NO. 2026-526

AN ORDINANCE AMENDING THE OFFICIAL ZONING MAP OF THE CITY OF TIFFIN, IOWA, TO REZONE THE ANDERSEN ADDITION – PART THREE FROM, R-12/OPD CONCEPT DISTRICT TO R-1C, IN THE CITY OF TIFFIN, IOWA, JOHNSON COUNTY, IOWA, AND AS LEGALLY DESCRIBED HEREIN

BE IT ENACTED BY THE CITY COUNCIL OF TIFFIN, IOWA:

Section 1. Purpose. The purpose of this ordinance is to amend the official zoning map of the City of Tiffin, Iowa, the Lotus Hill area of Andersen Addition – Part Three, Tiffin, Johnson County, Iowa, from R-12/OPD Concept District to R-1C, Single-Family.

Section 2. Amendment. The following legally described property:

DESCRIPTION - PROPOSED R-1C ZONING

BEGINNING at the Northeast Corner of said Southwest Quarter of the Northwest Quarter of Section 22, Township 80 North, Range 7 West, of the Fifth Principal Meridian, Tiffin, Johnson County, Iowa; Thence S00°50'43"E, along the East Line of said Southwest Quarter of the Northwest Quarter, 644.93 feet; Thence S89°29'44"W, 1033.85 feet; Thence N70°13'15"W, 124.30 feet; Thence N56°52'57"W, 109.95 feet; Thence S33°07'03"W, 36.61 feet. to a Point on the East Line of Andersen Addition - Part Two, in accordance with the Plat thereof Recorded in Plat Book 66 at Page 62 of the Records of the Johnson County Recorder's Office; Thence N56°52'57"W, along said East Line, 80.00 feet; Thence N33°07'03"E, along said East Line, 35.00 feet; Thence N56°52'57"W, along said East Line, 319.03 feet; Thence N50°01'23"W, along said East Line, 500.70 feet, to the Northeast Corner of said Andersen Addition - Part Two, and a Point on the North Line of the Southeast Quarter of the Northeast Quarter of Section 21, Township 80 North, Range 7 West, of the Fifth Principal Meridian; Thence N89°40'31"E, along said North Line, 620.00 feet, to the Northwest Corner of the Southwest Quarter of the Northwest Quarter of Section 21, Township 80 North, Range 7 West, of the Fifth Principal Meridian; Thence N89°34'17"E, along the North Line of said Southwest Quarter of the Northwest Quarter, 1332.18 feet, to the POINT OF BEGINNING. Said R-1C Zoning Parcel contains 22.97 Acres, and is subject to easements and restrictions of record.

shall be changed from zoning classification R-12/OPD, (Multi-family residential, 9 thru 12-plex Planned Development Overlay Concept District) to R-1C (Single-Family) and that the official zoning map of the City be amended to reflect the change described herein. Approval of this zoning classification change is subject to Council approval of a Developer's Agreement as required by the City, Council approval of the preliminary plat, compliance with the requirements of the Tiffin Zoning

Code and the Developer executing all easement agreements the City may require.

Section 3. Certification and Recording. Upon passage and approval of this ordinance, the City Clerk is hereby authorized and directed to certify a copy of this ordinance and to record the same, at the office of the County Recorder of Johnson County, Iowa, at the owner's expense, all as provided by law.

Section 4. Repealer. All ordinances or parts of ordinances in conflict with the provisions of this Ordinance are hereby repealed.

Section 5. Severability. If any section, provision, or part of this ordinance shall be adjudged to be invalid or unconstitutional, such adjudication shall not affect the validity of the ordinance as a whole, or any section, provision, or part thereof not adjudged invalid or unconstitutional.

Section 6. Effective Date. This ordinance shall be in effect after its final passage, approval, and posting as provided by law.

On the 7th day of April, 2026, at a regular meeting of the Tiffin City Council, Tiffin, Iowa, Councilperson Orris introduced Ordinance No. 2026-526, and moved that it be given its first reading. The motion was seconded by Councilperson Johnson.

Ayes: Orris, Olney, Johnson, Schnedler, Limkemann.

Nays: None.

Five members of the Council being present and having voted "Aye", Mayor Tim Kasperek declared the motion carried, and Ordinance No. 2026-526, was read the first time, discussed, and placed on record.

On the 21st day of April, 2026, at a regular meeting of the Tiffin City Council, Tiffin, Iowa, Councilperson Johnson introduced Ordinance No. 2026-526, and moved that it be given its second reading. The motion was seconded by Councilperson Orris.

Ayes: Olney, Johnson, Schnedler, Orris.

Nays: None.

Four members of the Council being present and having voted "Aye", Mayor Tim Kasperek declared the motion carried, and Ordinance No. 2026-526, was read the second time and discussed and placed on record.

On the 5th day of May, 2026, at a regular meeting of the Tiffin City Council, Tiffin, Iowa, Councilperson ____ introduced Ordinance No. 2026-526, and moved that it be given its third and last reading. The motion was seconded by Councilperson ____.

Ayes:
Nays:

_____ members of the Council being present and having voted "Aye", Mayor Tim Kasperek declared the motion carried, and the ordinance was passed and adopted.

Whereupon the Mayor declared that Ordinance No. 2026-526 be adopted and signified his approval of same by fixing his signature thereto. Passed by the Council on the _____th day of _____ 2026, and approved by the Mayor on the _____th day of _____ 2026.

CITY OF TIFFIN, IOWA:

By: _____
Tim Kasperek, Mayor

ATTEST:

Abigail Hora, City Clerk

I, Abigail Hora, City Clerk of the City of Tiffin, Iowa, state that an ordinance entitled AN ORDINANCE AMENDING THE OFFICIAL ZONING MAP OF THE CITY OF TIFFIN, IOWA, TO REZONE THE ANDERSEN ADDITION – PART THREE FROM, R-12/OPD CONCEPT DISTRICT TO R-1C, IN THE CITY OF TIFFIN, IOWA, JOHNSON COUNTY, IOWA, AND AS LEGALLY DESCRIBED HEREIN, and known as No. 2026-526 was duly passed by the Council on the _____th day of _____ 2026, and signed by the Mayor on the _____th day of _____ 2026, and published on the _____th day of _____ 2026, by posting copies thereof in three public places within the limits of the City of Tiffin, Iowa. That I posted copies of Ordinance No. 2026-526 in the following places:

The Depot, Tiffin, Iowa
Casey's, Tiffin, Iowa
Solon State Bank, Tiffin, Iowa

Abigail Hora, City Clerk

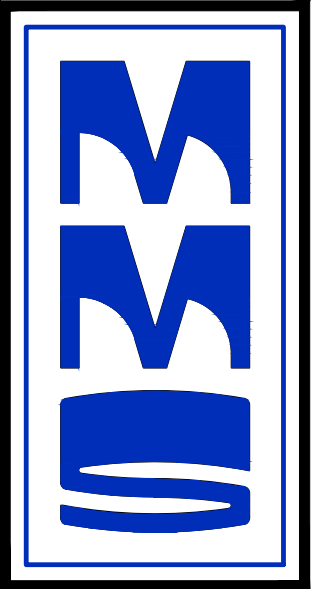

CIVIL ENGINEERS
LAND PLANNERS
LAND SURVEYORS
LANDSCAPE ARCHITECTS
ENVIRONMENTAL SPECIALISTS

1917 S. GILBERT ST.
IOWA CITY, IOWA 52240
(319) 351-8282
www.mmsconsultants.net

REZONING EXHIBIT

TIFFIN, JOHNSON COUNTY, IOWA

LEGEND AND NOTES	
	CONGRESSIONAL CORNER, FOUND
	PROPERTY CORNER(S), FOUND (as noted)
	PROPERTY CORNERS SET (5/8" Iron Pin w/ yellow, plastic LS Cap embossed with "MMS")
	CUT "X"
	PROPERTY &/or BOUNDARY LINES
	CONGRESSIONAL SECTION LINES
	RIGHT-OF-WAY LINES
	CENTER LINES
	LOT LINES, INTERNAL
	LOT LINES, PLATTED OR BY DEED
	EASEMENT LINES, WIDTH & PURPOSE NOTED
	EXISTING EASEMENT LINES, PURPOSE NOTED
	RECORDED DIMENSIONS
	MEASURED DIMENSIONS
	CURVE SEGMENT NUMBER

UNLESS NOTED OTHERWISE, ALL DIMENSIONS ARE IN FEET AND HUNDRETHS

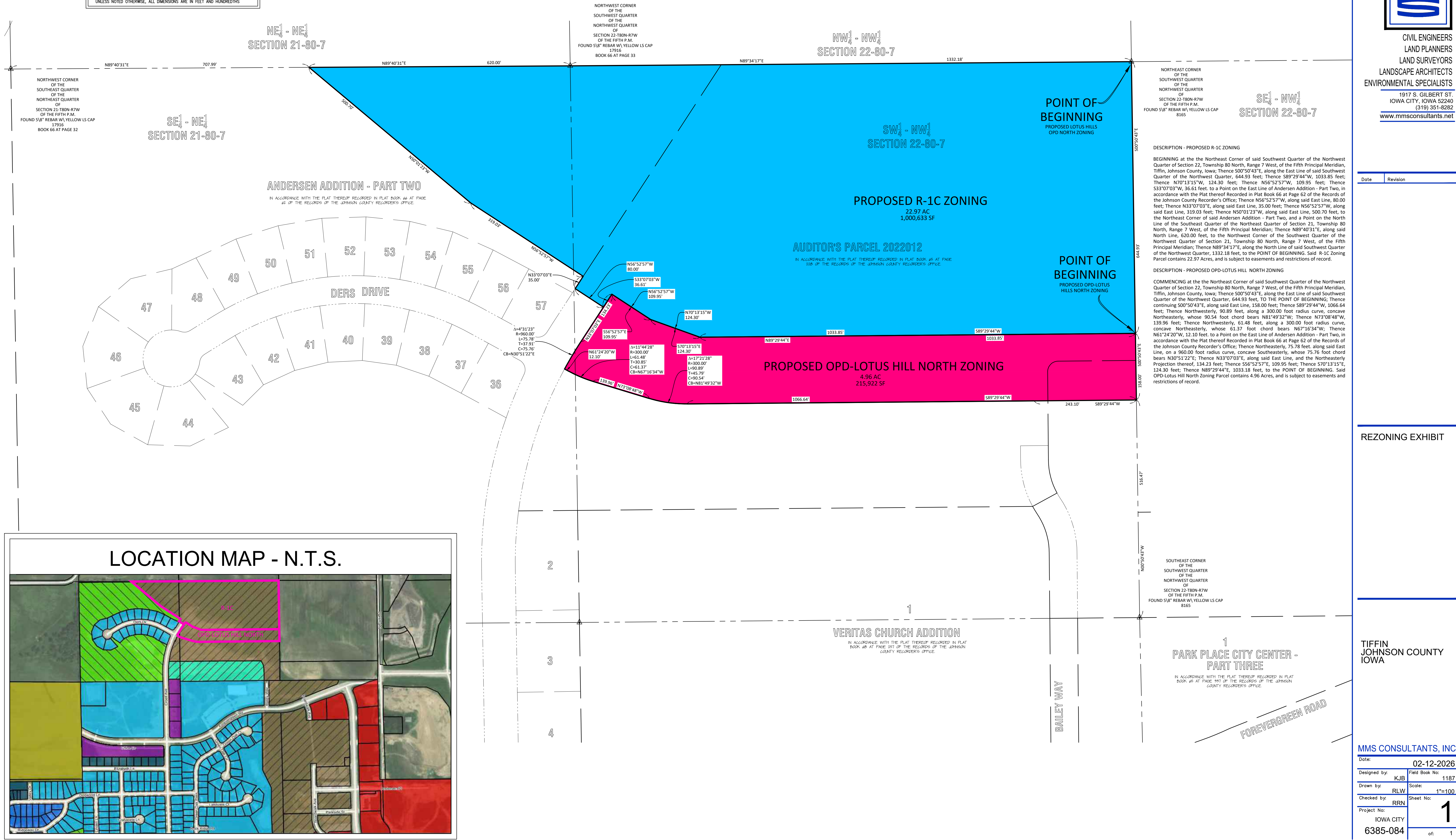
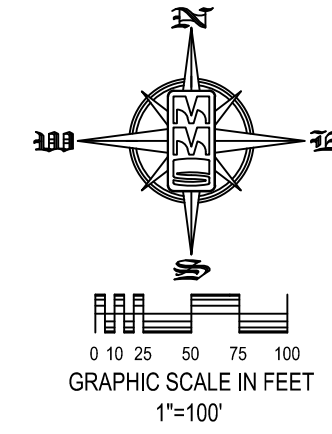

DESCRIPTION - PROPOSED R-1C ZONING

BEGINNING at the the Northeast Corner of said Southwest Quarter of the Northwest Quarter of Section 22, Township 80 North, Range 7 West, of the Fifth Principal Meridian, Tiffin, Johnson County, Iowa; Thence S00°50'43"E, along the East Line of said Southwest Quarter of the Northwest Quarter, 644.93 feet; Thence S89°29'44"W, 1033.85 feet; Thence N70°13'15"W, 124.30 feet; Thence N56°52'57"W, 109.95 feet; Thence S33°07'03"W, 36.61 feet, to a Point on the East Line of Andersen Addition - Part Two, in accordance with the Plat thereof Recorded in Plat Book 66 at Page 62 of the Records of the Johnson County Recorder's Office; Thence N56°52'57"W, along said East Line, 80.00 feet; Thence N33°07'03"E, along said East Line, 35.00 feet; Thence N56°52'57"W, along said East Line, 319.03 feet; Thence N50°01'23"W, along said East Line, 500.70 feet, to the Northeast Corner of said Andersen Addition - Part Two, and a Point on the North Line of the Southeast Quarter of the Northeast Quarter of Section 21, Township 80 North, Range 7 West, of the Fifth Principal Meridian; Thence N89°40'31"E, along said North Line, 620.00 feet, to the Northwest Corner of the Southwest Quarter of the Northwest Quarter of Section 21, Township 80 North, Range 7 West, of the Fifth Principal Meridian; Thence N89°34'17"E, along the North Line of said Southwest Quarter of the Northwest Quarter, 1332.18 feet, to the POINT OF BEGINNING. Said R-1C Zoning Parcel contains 22.97 Acres, and is subject to easements and restrictions of record.

DESCRIPTION - PROPOSED OPD-LOTUS HILL NORTH ZONING

COMMENCING at the the Northeast Corner of said Southwest Quarter of the Northwest Quarter of Section 22, Township 80 North, Range 7 West, of the Fifth Principal Meridian, Tiffin, Johnson County, Iowa; Thence S00°50'43"E, along the East Line of said Southwest Quarter of the Northwest Quarter, 644.93 feet, TO THE POINT OF BEGINNING; Thence continuing S00°50'43"E, along said East Line, 158.00 feet; Thence S89°29'44"W, 1066.64 feet; Thence Northwesterly, 90.89 feet, along a 300.00 foot radius curve, concave Northwesterly, whose 90.84 foot chord bears N81°49'32"W; Thence N73°08'48"W, 139.96 feet; Thence Northwesterly, 61.48 feet, along a 300.00 foot radius curve, concave Northwesterly, whose 61.37 foot chord bears N67°16'34"W; Thence N61°24'20"W, 12.10 feet, to a Point on the East Line of Andersen Addition - Part Two, in accordance with the Plat thereof Recorded in Plat Book 66 at Page 62 of the Records of the Johnson County Recorder's Office; Thence Northwesterly, 75.78 feet, along said East Line, on a 950.00 foot radius curve, concave Southeasterly, whose 75.76 foot chord bears N30°51'22"E; Thence N33°07'03"E, along said East Line, and the Northeastery Projection thereof, 134.23 feet; Thence S56°52'57"E, 109.95 feet; Thence S70°13'15"E, 124.30 feet; Thence N89°29'44"E, 1033.85 feet, to the POINT OF BEGINNING. Said OPD-Lotus Hill North Zoning Parcel contains 4.96 Acres, and is subject to easements and restrictions of record.

Date	Revision

REZONING EXHIBIT

TIFFIN
JOHNSON COUNTY
IOWA

MMS CONSULTANTS, INC.	
Date:	02-12-2026
Designed by:	KJB
Drawn by:	RLW
Checked by:	RRN
Project No:	IOWA CITY 6385-084
Field Book No:	1187
Scale:	1"=100'
Sheet No:	1
of:	1

LOCATION MAP - N.T.S.

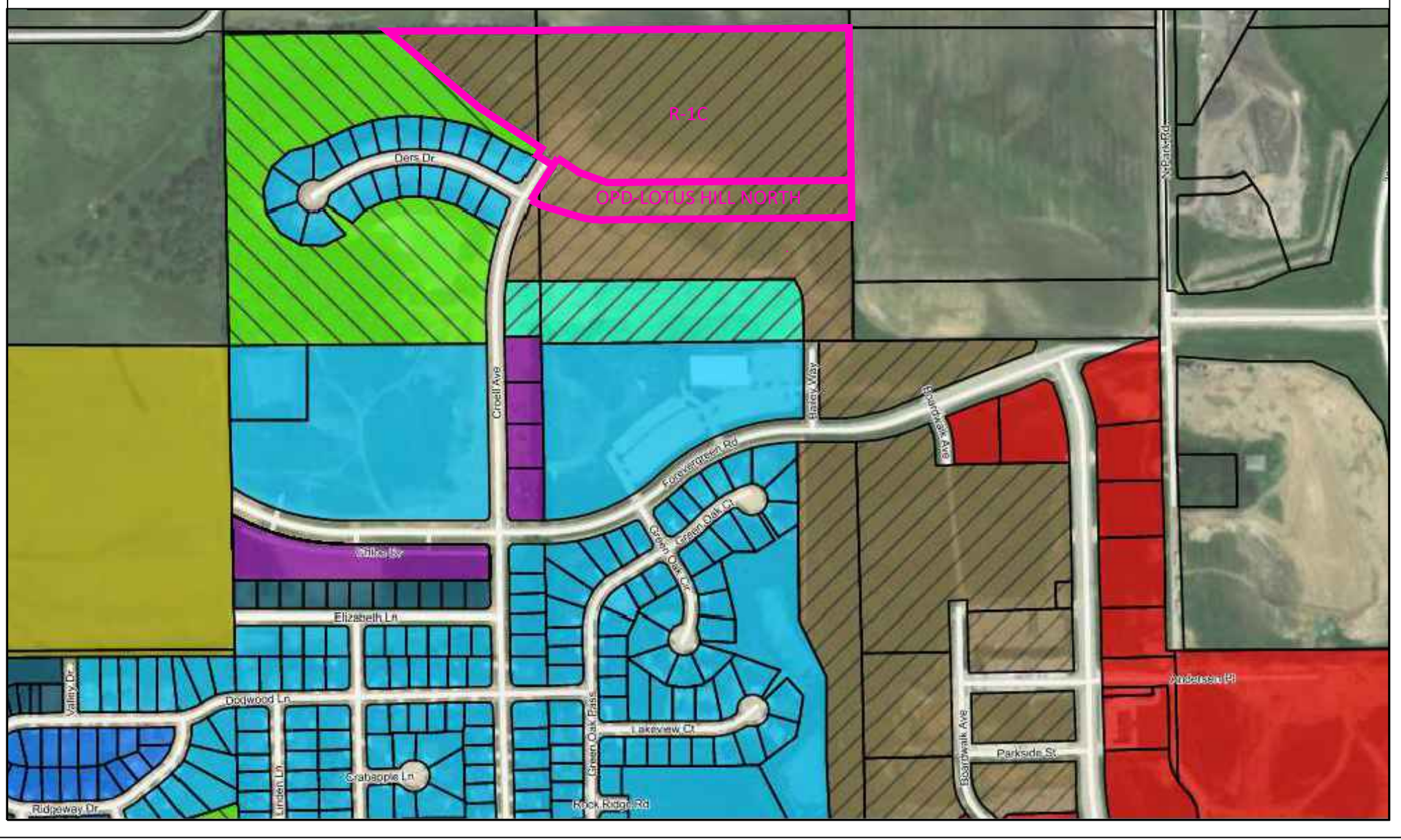

CITY OF TIFFIN ORDINANCE NO. 2026-527

AN ORDINANCE AMENDING THE OFFICIAL ZONING MAP OF THE CITY OF TIFFIN, IOWA, TO REZONE PROPERTY LOCATED IN TIFFIN HEIGHTS WEST FROM C-2B (GENERAL COMMERCIAL) TO P-1 (PUBLIC/INSTITUTIONAL), IN THE CITY OF TIFFIN, JOHNSON COUNTY, IOWA, AS LEGALLY DESCRIBED HEREIN

BE IT ENACTED BY THE CITY COUNCIL OF TIFFIN, IOWA:

Section 1. Purpose. The purpose of this ordinance is to amend the Official Zoning Map of the City of Tiffin, Iowa, to rezone certain property located in Tiffin Heights West, Tiffin, Johnson County, Iowa, from C-2B, General Commercial, to P-1, Public/Institutional, as requested by the applicant and owner, GHS Development.

Section 2. Amendment. The following legally described property:

DESCRIPTION – PROPOSED P-1 ZONING

Lots 56, 57, and 58 of Tiffin Heights West, being a portion of the southeast Quarter of the Northwest Quarter of Section 29, Township 80 North, Range 7 West of the Fifth Principal Meridian, Tiffin, Johnson County, Iowa, in accordance with the plat thereof recorded in Plat Book 69 at Page 137 of the records of the Johnson County Recorder's Office.

Said parcel contains approximately 4.97 acres, and is subject to easements and restrictions of record.

shall be rezoned from C-2B (General Commercial) to P-1 (Public/Institutional), and the Official Zoning Map of the City of Tiffin is hereby amended to reflect this change.

Approval of this zoning classification change is subject to compliance with all applicable requirements of the Tiffin Zoning Code, subdivision regulations, and any other applicable City ordinances, resolutions, or agreements.

Section 3. Certification and Recording. Upon passage and approval of this ordinance, the City Clerk is hereby authorized and directed to certify a copy of this ordinance and to record the same, at the office of the County Recorder of Johnson County, Iowa, at the owner's expense, all as provided by law.

Section 4. Repealer. All ordinances or parts of ordinances in conflict with the provisions of this Ordinance are hereby repealed.

Section 5. Severability. If any section, provision, or part of this ordinance shall be adjudged to be invalid or unconstitutional, such adjudication shall not affect the validity of the ordinance as a whole, or any section, provision, or part thereof not adjudged invalid or unconstitutional.

Section 6. Effective Date. This ordinance shall be in effect after its final passage, approval, and posting as provided by law.

On the 21st day of April, 2026, at a regular meeting of the Tiffin City Council, Tiffin, Iowa, Councilperson Orris introduced Ordinance No. 2026-527, and moved that it be given its first reading. The motion was seconded by Councilperson Schnedler.

Ayes: Orris, Olney, Johnson, Schnedler.
Nays: None.

Four members of the Council being present and having voted "Aye", Mayor Tim Kasparek declared the motion carried, and Ordinance No. 2026-526, was read the first time, discussed, and placed on record.

On the 5th day of May, 2026, at a regular meeting of the Tiffin City Council, Tiffin, Iowa, Councilperson _____ introduced Ordinance No. 2026-526, and moved that it be given its second reading. The motion was seconded by Councilperson _____.

Ayes:
Nays:

_____ members of the Council being present and having voted "Aye", Mayor Tim Kasparek declared the motion carried, and Ordinance No. 2026-526, was read the second time and discussed and placed on record.

On the _____ day of _____, 2026, at a regular meeting of the Tiffin City Council, Tiffin, Iowa, Councilperson _____ introduced Ordinance No. 2026-527, and moved that it be given its third and last reading. The motion was seconded by Councilperson _____.

Ayes:
Nays:

_____ members of the Council being present and having voted "Aye", Mayor Tim Kasparek declared the motion carried, and the ordinance was passed and adopted.

Whereupon the Mayor declared that Ordinance No. 2026-527 be adopted and signified his approval of same by fixing his signature thereto. Passed

by the Council on the ____th day of ____ 2026, and approved by the Mayor on the ____th day of ____ 2026.

CITY OF TIFFIN, IOWA:

By: _____
Tim Kasparek, Mayor

ATTEST:

Abigail Hora, City Clerk

I, Abigail Hora, City Clerk of the City of Tiffin, Iowa, state that an ordinance entitled AN ORDINANCE AMENDING THE OFFICIAL ZONING MAP OF THE CITY OF TIFFIN, IOWA, TO REZONE PROPERTY LOCATED IN TIFFIN HEIGHTS WEST FROM C-2B (GENERAL COMMERCIAL) TO P-1 (PUBLIC/INSTITUTIONAL), IN THE CITY OF TIFFIN, JOHNSON COUNTY, IOWA, AS LEGALLY DESCRIBED HEREIN, and known as No. 2026-526 was duly passed by the Council on the ____th day of ____ 2026, and signed by the Mayor on the ____th day of ____ 2026, and published on the ____th day of ____ 2026, by posting copies thereof in three public places within the limits of the City of Tiffin, Iowa. That I posted copies of Ordinance No. 2026-527 in the following places:

The Depot, Tiffin, Iowa
Casey's, Tiffin, Iowa
Solon State Bank, Tiffin, Iowa

Abigail Hora, City Clerk

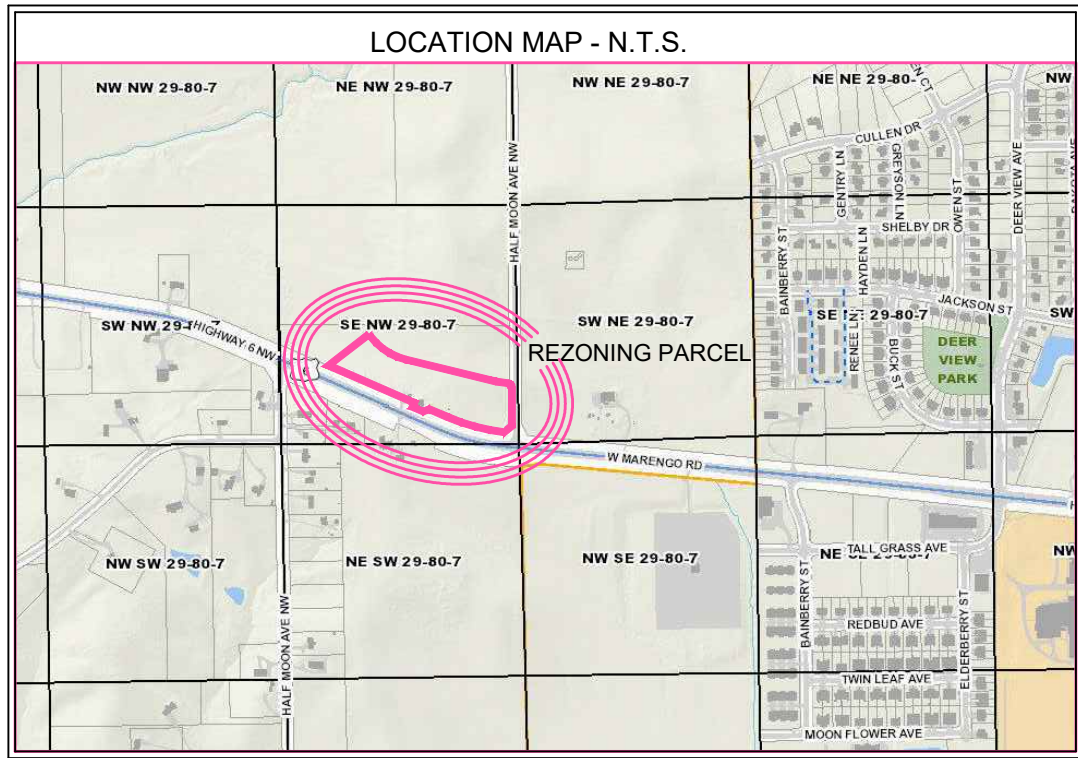

LOCATION:
 LOTS 56, 57, AND 58 OF TIFFIN HEIGHTS WEST, BEING A PORTION OF THE SOUTHEAST QUARTER OF THE NORTHWEST QUARTER OF SECTION 29-T80N-R7W OF THE FIFTH PRINCIPAL MERIDIAN, TIFFIN, JOHNSON COUNTY, IOWA

APPLICANT:
 GHS DEVELOPMENT
 PO BOX 78
 NORTH LIBERTY, IOWA 52317

PROPRIETOR OR OWNER:
 GHS DEVELOPMENT
 PO BOX 78
 NORTH LIBERTY, IOWA 52317

REZONING EXHIBIT

TIFFIN HEIGHTS WEST

TIFFIN, IOWA

LEGEND AND NOTES	
	- CONGRESSIONAL CORNER, FOUND
	- PROPERTY &/or BOUNDARY LINES
	- CONGRESSIONAL SECTION LINES
	- RIGHT-OF-WAY LINES
	- CENTER LINES
	- EXISTING ZONING LINES
	- LOT LINES, PLATTED OR BY DEED
	- EASEMENT LINES, WIDTH & PURPOSE NOTED
	- EXISTING EASEMENT LINES, PURPOSE NOTED

UNLESS NOTED OTHERWISE, ALL DIMENSIONS ARE IN FEET AND HUNDREDTHS



CIVIL ENGINEERS
 LAND PLANNERS
 LAND SURVEYORS
 LANDSCAPE ARCHITECTS
 ENVIRONMENTAL SPECIALISTS

1917 S. GILBERT ST.
 IOWA CITY, IOWA 52240
 (319) 351-8282
www.mmsconsultants.net

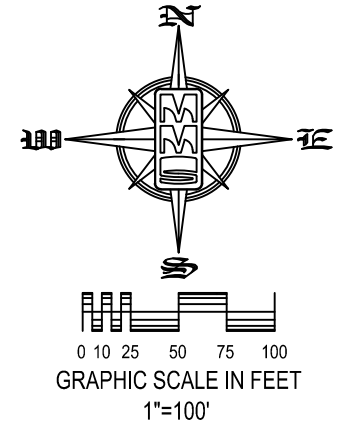
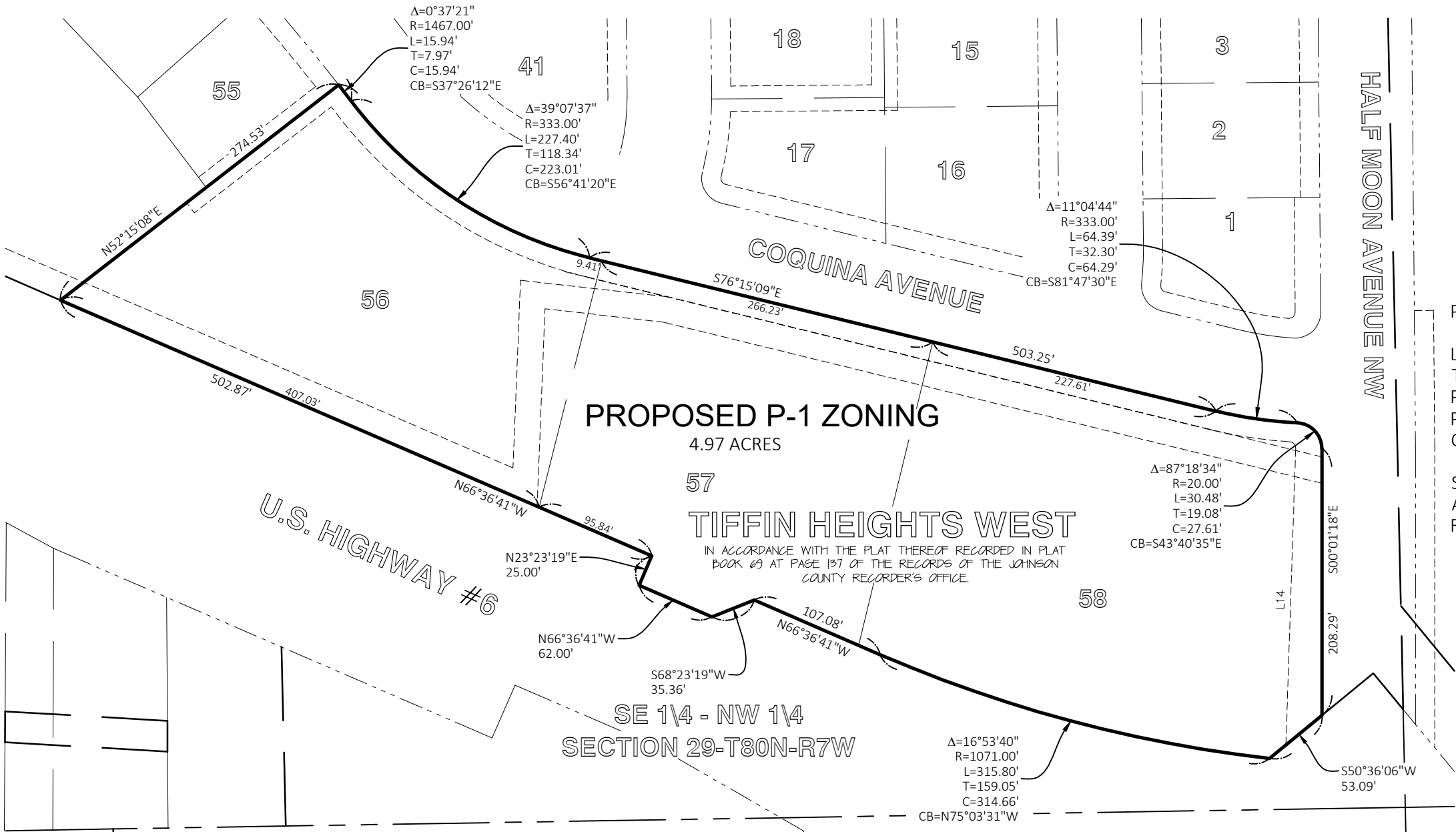

PROPOSED P-1 ZONING PARCEL

LOTS 56, 57, AND 58 OF TIFFIN HEIGHTS WEST, TO TIFFIN, IOWA, IN ACCORDANCE WITH THE PLAT THEREOF RECORDED IN PLAT BOOK 69 AT PAGE 137 OF THE RECORDS OF THE JOHNSON COUNTY RECORDER'S OFFICE.

SAID P-1 ZONING PARCEL CONTAINS 4.97 ACRES, AND IS SUBJECT TO EASEMENTS AND RESTRICTIONS OF RECORD.

Date	Revision

REZONING EXHIBIT

TIFFIN
 JOHNSON COUNTY
 IOWA

MMS CONSULTANTS, INC.

Date:	04-03-2026
Designed by:	JDM
Field Book No.:	1374
Drawn by:	RLW
Scale:	1"=100'
Checked by:	RRN
Sheet No.:	1
Project No.:	9315-012
of:	1

RESOLUTION NO. 2026-028

A RESOLUTION SETTING THE DATE OF MAY 19, 2026, FOR A PUBLIC HEARING FOR THE FY 2025-2026 BUDGET AMENDMENT

Whereas, The City recognizes there should be a budget amendment to update the necessary revenues and expenses that have transpired in FY 2025-2026 that were not originally planned;

Now, therefore be it resolved by the City Council of the City of Tiffin, Iowa to approve setting a public hearing date for May 19, 2026, for the Budget Amendment.

On the 5th day of May, at a regular meeting of the Tiffin City Council, Tiffin, Iowa, Councilperson ___ introduced **RESOLUTION NO. 2026-028, A RESOLUTION SETTING THE DATE OF MAY 19, 2026, FOR A PUBLIC HEARING DATE FOR THE FY 2025-2026 BUDGET AMENDMENT** and made a motion for approval. Motion seconded by Councilperson _____.

Ayes:.
Nays:
Absent:

Whereupon ___ Council members were present and voted approval and Mayor Kasperek declared that the **RESOLUTION NO. 2026-028, A RESOLUTION SETTING THE DATE OF MAY 19, 2026, FOR A PUBLIC HEARING DATE FOR THE FY 2025-2026 BUDGET AMENDMENT** to be adopted and signified his approval of the same by affixing his signature thereto.

Passed by the City Council on the 5th day of May, 2026.

City of Tiffin

Tim Kasperek, Mayor

ATTEST: _____
Abigail Hora, City Clerk



AGENDA INFORMATION
TIFFIN CITY COUNCIL COMMUNICATION

DATE:	May 1, 2026
AGENDA ITEM:	Resolution No. 2026-029 – A Resolution Certifying the 2025 Special Federal Census for the City of Tiffin to the Iowa Secretary of State and the Treasurer of the State of Iowa
ACTION:	Motion

Background

The primary purpose of this agenda item is for the City Council to certify the 2025 Special Federal Census by resolution. The U.S. Census Bureau conducted the Special Census at the City’s request due to significant residential growth occurring since the 2020 decennial census.

On April 9, 2026, the U.S. Census Bureau issued a Director’s Letter confirming the official results of the Special Census. The certified population for the City of Tiffin is 7,577 residents, with a certified housing unit count of 3,394. This represents an increase of 3,065 residents compared to the 2020 Census population of 4,512.

State agencies require the updated population figures to be certified by resolution at the local level before they can be used for state funding formulas and administrative purposes. Approval of the resolution allows the City to formally submit the certified Special Census results to the Iowa Secretary of State and the Treasurer of the State of Iowa.

Recommendation

It is staff’s recommendation that the City Council approve Resolution No. 2026-029, certifying the 2025 Special Federal Census for the City of Tiffin to the Iowa Secretary of State and the Treasurer of the State of Iowa.

ATTACHMENTS: Resolution

RESOLUTION NO. 2026-029

A RESOLUTION CERTIFYING THE 2025 SPECIAL FEDERAL CENSUS FOR THE CITY OF TIFFIN TO THE IOWA SECRETARY OF STATE AND THE TREASURER OF THE STATE OF IOWA

Whereas, in 2025, a Special Federal Census was completed for the City of Tiffin, Iowa; and,

Whereas, the Mayor and City Council of the City of Tiffin, Iowa, desire to certify the 2025 Special Federal Census for the City of Tiffin, Iowa, to the Iowa Secretary of State and the Treasurer of the State of Iowa pursuant to Iowa Code Section 9F.6; and,

Whereas, the certified population for the City of Tiffin, Iowa, in 2020, was 4,512 and as a result of the 2025 Special Census, the certified population of the City of Tiffin will be 7,577 with a housing unit count was 3,394.

Now, therefore be it resolved, by the City Council of the City of Tiffin, Iowa, that the 2025 Special Federal Census, as set forth in the attached Exhibit A, is hereby certified to the Iowa Secretary of State and the Treasurer of the State of Iowa.

On the 5th day of May, 2026, at a regular meeting of the Tiffin City Council, Tiffin, Iowa, Councilperson _____ introduced **RESOLUTION NO. 2026-029, A RESOLUTION CERTIFYING THE 2025 SPECIAL FEDERAL CENSUS FOR THE CITY OF TIFFIN TO THE IOWA SECRETARY OF STATE AND THE TREASURER OF THE STATE OF IOWA** and made a motion for approval. Motion seconded by Councilperson _____.

Ayes:
Nays:
Absent:

Whereupon _____ Council members were present and voted approval and Mayor Kasparek declared that the **RESOLUTION NO. 2026-029, A RESOLUTION CERTIFYING THE 2025 SPECIAL FEDERAL CENSUS FOR THE CITY OF TIFFIN TO THE IOWA SECRETARY OF STATE AND THE TREASURER OF THE STATE OF IOWA** to be adopted and signified his approval of the same by affixing his signature thereto.

Passed by the City Council on the 5th day of May, 2026.

City of Tiffin

Tim Kasparek, Mayor

ATTEST: _____
Abigail Hora, City Clerk



UNITED STATES DEPARTMENT OF COMMERCE
U.S. Census Bureau
Office of the Director
Washington, DC 20233-0001

April 9, 2026

Mr. Tim Kasperek
Mayor of Tiffin, Iowa
300 Railroad St.
Tiffin, IA 52340

Dear Mr. Tim Kasperek,

We are pleased to inform you of the results of a full special census of the City of Tiffin, Iowa that has been conducted.

As of October 15, 2025, the population of your special census area was 7,577 and the housing unit count was 3,394. These numbers represent "Official Census Statistics" according to Title 13 United States Code Section 196, and may be used in the manner provided by applicable law. The attached data product(s) include:

- Total population and total housing unit counts by block for the special census area and
- A demographic profile that contains similar content as the 2020 Census demographic profiles.

You will receive final accounting of the cost of your special census within approximately 120 calendar days of receiving this letter. The advance payment of the estimate will be adjusted to actual costs, and additional billing or refund will be made, as appropriate.

If you require further information concerning this special census, please contact the Special Census Program at DCMD.Special.Census@census.gov.

Sincerely,

George M. Cook

Performing the functions and duties of
the Director at the U.S. Census Bureau

Attachments



AGENDA INFORMATION
TIFFIN CITY COUNCIL COMMUNICATION

DATE:	May 1, 2026
AGENDA ITEM:	Resolution No. 2026-030 – A Resolution to Update the Petty Cash/Change Fund and Policies on Use Thereof
ACTION:	Motion

Background

The City maintains petty cash and change funds for City Hall and Parks & Recreation operations to allow for small purchases and to make change where cash is collected. Historically, the City has provided coin change as part of these transactions.

Recently, the City’s financial institution has ceased providing pennies, and pennies are becoming increasingly uncommon in circulation. As a result, maintaining the ability to provide exact coin change is no longer practical or sustainable. This has prompted a review of existing petty cash and change fund policies.

The proposed resolution improves consistency and transparency in cash handling practices and reflects modern banking limitations. Eliminating coin change reduces administrative burden and risk while still allowing residents flexible payment options through account credits or alternative payment methods.

This update does not change the fundamental purpose of petty cash but ensures the policy is practical, enforceable, and aligned with current financial operations.

Staff Recommendation

Staff recommends approval of Resolution No. 2026-030, updating the Petty Cash and Change Fund policies to reflect current banking practices and operational needs.

ATTACHMENTS: Resolution

RESOLUTION 2026-030

A RESOLUTION TO UPDATE THE PETTY CASH/CHANGE FUND AND POLICIES ON USE THEREOF

WHEREAS, the City of Tiffin City intends by this Resolution to adopt a system for the authorization, control, implementation and the administration of a Petty Cash/Change Fund by City Hall Employees and Concession Employees; and

WHEREAS, the City Council of the City of Tiffin City desires to approve and adopt the policy and procedures for a Petty Cash/Change Fund as being in the best interest of the City of Tiffin City;

WHEREAS, with pennies no longer being produced and becoming less common in circulation, providing coin change has become increasingly impractical;

NOW, THEREFORE BE IT RESOLVED that the City Council shall implement the following policies and procedures for the authorization, control, implementation and administration of a petty cash fund by City Hall Employees and Parks Employees as follows:

ESTABLISH AND ADMINISTER PETTY CASH AND CHANGE FUNDS

Purpose:

To establish official procedures and guidelines for Petty Cash/Change Fund for City Hall and Concession employees.

Definitions:

1. Petty Cash – A sum of money set aside for the purpose of paying small obligations for which the issuance of a payment request and warrant would not be cost-effective.
2. Change Fund – A sum of money set aside for the purpose of making change where cash is collected.
3. Custodian – Person in charge of balancing said fund; this being the City Clerk for City Hall and the Parks & Recreation Director.

Policies:

1. The Petty Cash and Change Fund will be one in the same further known as Petty Cash.
2. Petty cash funds shall be balanced monthly, by the custodian, then verified and signed by the City Clerk or Deputy City Clerk. All copies of the balanced monthly sheet shall be kept for yearly audit review.
3. At the end of each month, the petty cash fund for the City Hall shall be reimbursed to its imprest amount of \$200. The Concessions shall be reimbursed to its imprest amount of \$800.
4. City Hall Change Fund shall be reconciled daily, and deposits shall be made daily to the City's Financial Institution.
5. Park Concessions Change Fund shall be reconciled daily and shall not exceed \$800. Concessions will make deposits daily as needed
6. Petty Cash shall be used for legitimate City purchases only.
7. Petty Cash shall not be used for personal cash advances or to cash personal checks.

8. Petty cash that is advanced for approved purchases must have a receipt for purchase and any change returned to the petty cash fund by the custodian and signed by the custodian.
9. Cash Handling/Change Policy:
 - A. Cash payment received at City Hall shall be applied in full to the customer's account
 - B. The City shall not provide coin change for cash transactions.
 - C. Any overpayment shall be credited to the customer's account
 - D. Residents are encouraged to provide exact change to utilize alternative payment methods.
10. The custodian shall ensure that the following represents the authorized petty cash amount:
 - a. Cash on Hand
 - b. Cash disbursements represented by receipts
 - c. Cash income represented by income register form.
11. Receipts shall be deposited to the depository bank account intact monthly leaving the fund constant.

Fines & Penalties:

Any employee or elected official who ensures unauthorized costs shall be held personally liable for all said costs.

On the 5th day of May, 2026, at a regular meeting of the Tiffin City Council, Tiffin, Iowa, Councilperson _____ introduced **RESOLUTION NO. 2026-030, A RESOLUTION TO UPDATE THE PETTY CASH/CHANGE FUND AND POLICIES ON USE THEREOF** and made a motion for approval. Motion seconded by Councilperson _____.

Ayes:
Nays:
Absent:

Whereupon ___ Council members were present and voted approval and Mayor Kasperek declared that the **RESOLUTION NO. 2026-030, A RESOLUTION TO UPDATE THE PETTY CASH/CHANGE FUND AND POLICIES ON USE THEREOF** to be adopted and signified his approval of the same by affixing his signature thereto.

Passed by the City Council on the 5th day of May 2026.

Tim Kasperek, Mayor

ATTEST:

Abigail Hora, City Clerk

RESOLUTION NO. 2026-031

A RESOLUTION TO APPROVE MODIFICATIONS TO THE OPD BUILDING RENDERINGS FOR LOTUS HILL SOUTH, TIFFIN, IOWA

Whereas, the Developer of Lotus Hill South in Andersen Addition has proposed to make changes to the OPD building renderings; and,

Whereas, OPD .07, subsection K, of Ordinance 2017-393 allows for 'Modifications to Plans Prior to Completion of Initial Construction' to be approved by the City Council; and,

Whereas, the modifications are attached to this resolution; and,

Whereas, the attached minor modifications have been reviewed by City Staff and the City Attorney and recommend approval,

Now, therefore be it resolved by the City Council of the City of Tiffin, Iowa to approve the building rendering modifications to the OPD for Lotus Hill South, Tiffin, Iowa.

On the 5th day of May, 2026, at a regular meeting of the Tiffin City Council, Tiffin, Iowa, Councilperson _____ introduced **RESOLUTION NO. 2026-031, A RESOLUTION TO APPROVE MODIFICATIONS TO THE OPD BUILDING RENDERINGS FOR LOTUS HILL SOUTH, TIFFIN, IOWA** and made a motion for approval. Motion seconded by Councilperson _____.

Ayes:

Nays:

Absent:

Whereupon _____ Council members were present and voted approval and Mayor Kasperek declared that **RESOLUTION NO. 2026-031, A RESOLUTION TO APPROVE MODIFICATIONS TO THE OPD BUILDING RENDERINGS FOR LOTUS HILL SOUTH, TIFFIN, IOWA** to be adopted and signified his approval of the same by affixing his signature thereto.

Passed by the City Council on the 5th day of May, 2026.

City of Tiffin

Tim Kasperek, Mayor

ATTEST: _____
Abigail Hora, City Clerk

OPTION ONE



OPTION TWO



OPTION THREE

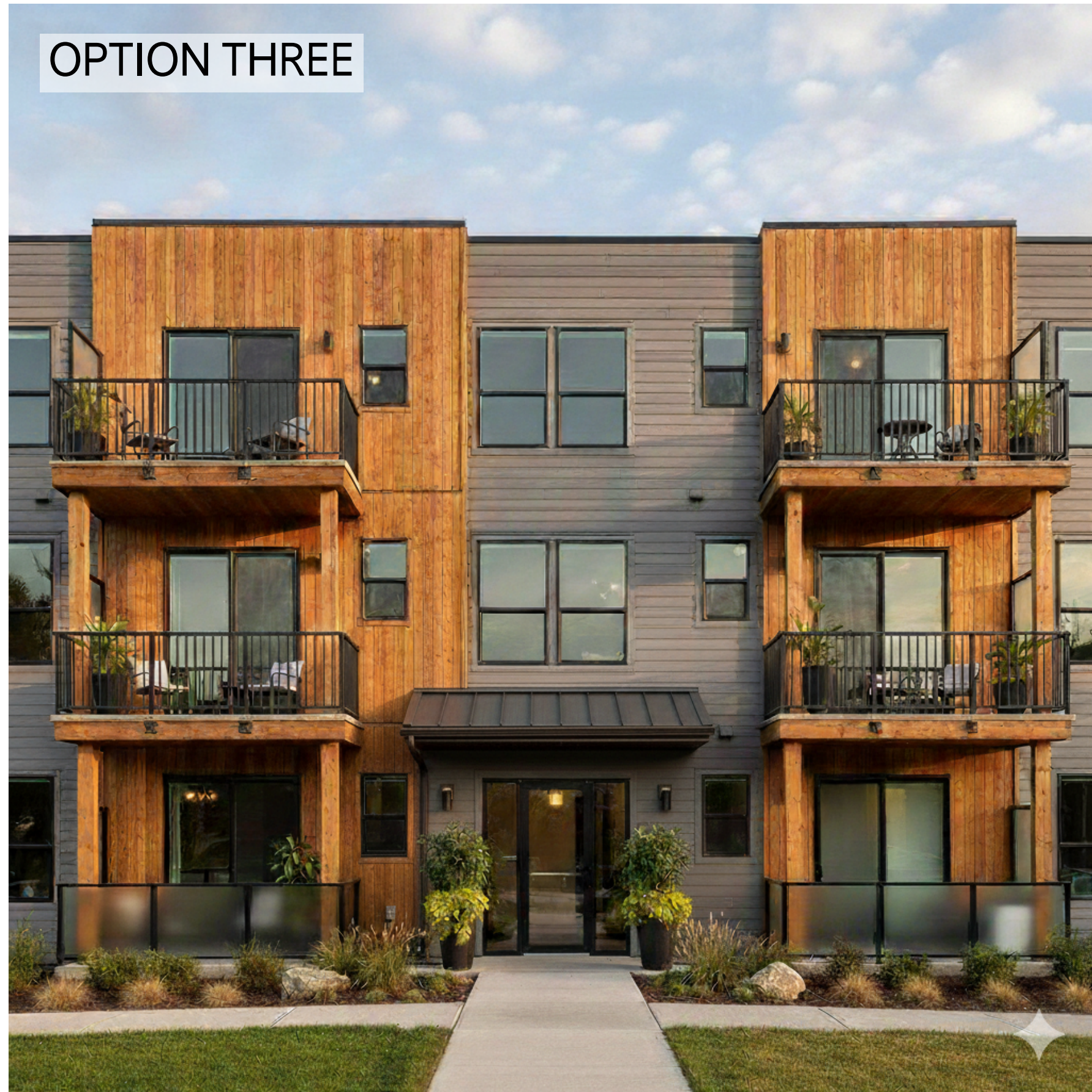

OPTION FOUR



**LOTUS
HILL
SOUTH**

RESOLUTION NO. 2026-032

A RESOLUTION APPROVING THE AMENDED PRELIMINARY PLAT OF ANDERSEN ADDITION – PART THREE, TIFFIN, IOWA

Whereas, MMS Consultants Inc., on behalf of Hightower Development, Inc., has filed with the City of Tiffin an amended preliminary plat for Andersen Addition – Part Three, a subdivision to the City of Tiffin, Iowa, legally described on the attached Exhibit; and,

Whereas, the Tiffin Planning & Zoning Commission has reviewed and recommended for approval on a 3-0 vote the preliminary plat at its March 2026 meeting; and,

Whereas, The City Staff and the City Attorney has reviewed and given their recommendations for the preliminary plat; and,

Whereas, MSA Professional Services has given their review and comments of said preliminary plat and subject to certain revisions, provided however that no improvements shall be constructed or installed without their written approval, which may be withheld until such time as all necessary permits have been issued from the state and federal agencies.

Now, therefore be it resolved by the City Council of the City of Tiffin, Iowa, that the Amended Preliminary Plat for Andersen Addition – Part Three is hereby approved; and further that the Mayor and City Clerk are hereby authorized and directed to execute any documents necessary at this time to approve the preliminary plat as submitted and as approved by the City Engineer and City Attorney.

On the 5th day of May, 2026, at a regular meeting of the Tiffin City Council, Tiffin, Iowa, Councilperson _____ introduced **RESOLUTION NO. 2026-032, A RESOLUTION APPROVING THE AMENDED PRELIMINARY PLAT OF ANDERSEN ADDITION – PART THREE, TIFFIN, IOWA**, and made a motion for approval. Motion seconded by Councilperson _____.

Ayes:

Nays:

Whereupon _____ Council members were present and voted approval and Mayor Kasperek declared that **RESOLUTION NO. 2026-032, A RESOLUTION APPROVING THE AMENDED PRELIMINARY PLAT OF ANDERSEN ADDITION – PART THREE, TIFFIN, IOWA**, to be adopted and signified his approval of the same by affixing his signature thereto.

Passed by the City Council on the 5th day of May, 2026.

City of Tiffin

Tim Kasperek, Mayor

ATTEST: _____
Abigail Hora, City Clerk



CIVIL ENGINEERS
LAND PLANNERS
LAND SURVEYORS
LANDSCAPE ARCHITECTS
ENVIRONMENTAL SPECIALISTS

1917 S. GILBERT ST.
IOWA CITY, IOWA 52240
(319) 351-8282
www.mmsconsultants.net

Table with 2 columns: Date, Revision. Includes dates 03-13-26 and 04-27-26 with corresponding revision descriptions.

AMENDED PRELIMINARY PLAT

ANDERSEN ADDITION - PART THREE
TIFFIN JOHNSON COUNTY, IOWA

Project information table including Date (02-13-26), Designer (KJB), Drawn by (TAV), Checked by (RAN), and Project No (6385-084).

AMENDED PRELIMINARY PLAT
ANDERSEN ADDITION - PART THREE
TIFFIN, IOWA

PLAT/PLAN APPROVED by the City of Tiffin. Includes Mayor and Date fields.

PRELIMINARY PLAT DESCRIPTION - ANDERSEN ADDITION PART THREE

BEGINNING at the Southeast Corner of the Southwest Quarter of the Northwest Quarter of Section 22, Township 80 North, Range 7 West, of the Fifth Principal Meridian, Tiffin, Johnson County, Iowa; Thence S89°30'03"W, along the North Line of Park Place City Center - Part Three, in accordance with the Plat thereof Recorded in Plat Book 65 at Page 337 of the Records of the Johnson County Recorder's Office, 147.17 feet, to the Northwest Corner thereof; Thence N00°30'16"W, along the East Right-of-Way Line of Bailey Way, 155.96 feet; Thence Northwestwesterly, 135.76 feet, along said East Right-of-Way Line, on a 233.00 foot radius curve, concave Southwesterly, whose 333.85 foot chord bears N171°14'48"W; Thence Northwestwesterly, 97.30 feet, along said East Right-of-Way Line, on a 167.00 foot radius curve, concave Northeastwesterly, whose 95.93 foot chord bears N171°14'48"W; Thence N00°30'16"W, along said East Right-of-Way Line, 34.14 feet; Thence S89°30'03"W, along the North Line of said East Right-of-Way Line, on a 960.00 foot radius curve, concave Southeastwesterly, whose 428.26 foot chord bears N20°13'44"E; Thence N33°07'03"E, along said East Line, 97.62 feet; Thence N56°52'57"W, along said East Line, 80.00 feet; Thence N33°07'03"E, along said East Line, 35.00 feet; Thence N56°52'57"W, along said East Line, 319.03 feet; Thence S50°12'12"W, along said East Line, 500.70 feet, to the Northeast Corner of said Andersen Addition - Part Two, and a Point on the North Line of the Southeast Quarter of the Northeast Quarter of Section 21, Township 80 North, Range 7 West, of the Fifth Principal Meridian; Thence N89°34'17"E, along the North Line of said Southwest Quarter of the Northwest Quarter, 1332.18 feet, to the Northeast Corner of said Southwest Quarter of the Northwest Quarter; Thence S00°50'43"E, along the East Line of said Southwest Quarter of the Northwest Quarter, 1319.40 feet, to the POINT OF BEGINNING. Said ANDERSEN ADDITION PART THREE contains 37.16 Acres, and is subject to easements and restrictions of record.

Zoning table with columns: LOTS, ZONING, SETBACKS (VARIES PER USE). Includes setbacks for Front, Rear, Side, and Street Corner for lots 1-26, 27-56, 57-68, and 69-70.

PLAT PREPARED BY: MMS CONSULTANTS INC. 1917 S. GILBERT STREET IOWA CITY, IA 52240
OWNER: HIGHTOWER DEVELOPMENT, INC PO BOX 5198 CORALVILLE, IA 52241
APPLICANT: HIGHTOWER DEVELOPMENT, INC PO BOX 5198 CORALVILLE, IA 52241
APPLICANT'S ATTORNEY: MATTHEW J. HEKTOEN SIMMONS PERRINE MOYER BERGMAN PLC 115 3RD STREET SE, SUITE 1200 CEDAR RAPIDS, IA 52401

- NOTES:
1. ALL EASEMENTS ARE 15 FOOT UTILITY EASEMENTS UNLESS NOTED OTHERWISE. EASEMENTS SHOWN ADJACENT TO PUBLIC RIGHT-OF-WAY SHALL INCLUDE UTILITY SERVICE BY COMMERCIAL PROVIDERS.
2. THE SITE DOES NOT LIE WITHIN ANY FEMA DESIGNATED ZONES.
3. NO DIRECT VEHICULAR ACCESS IS ALLOWED FROM LOTS ADJACENT TO CROELL AVENUE EXCEPT THE SHARED ACCESS ON LOT 63.

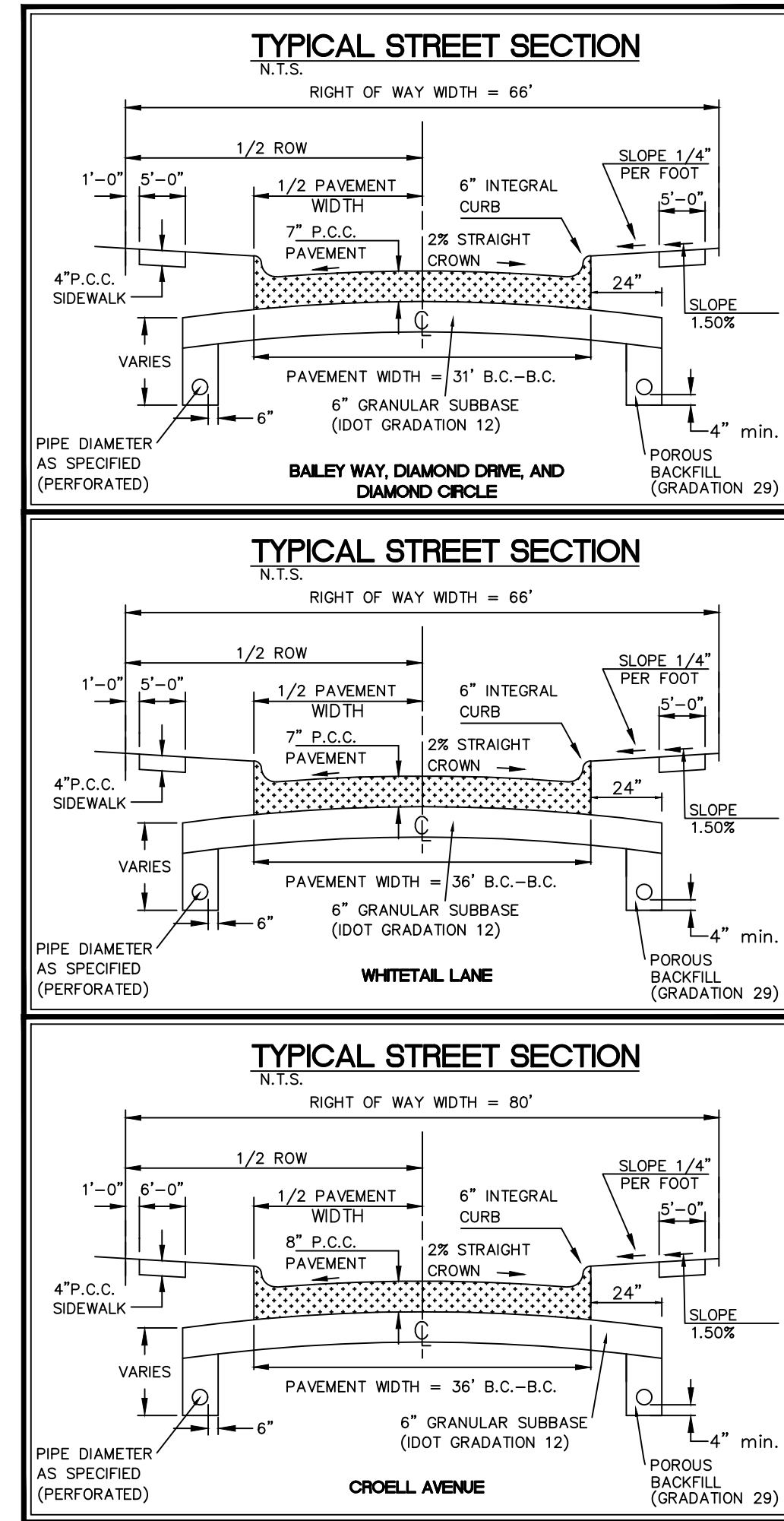
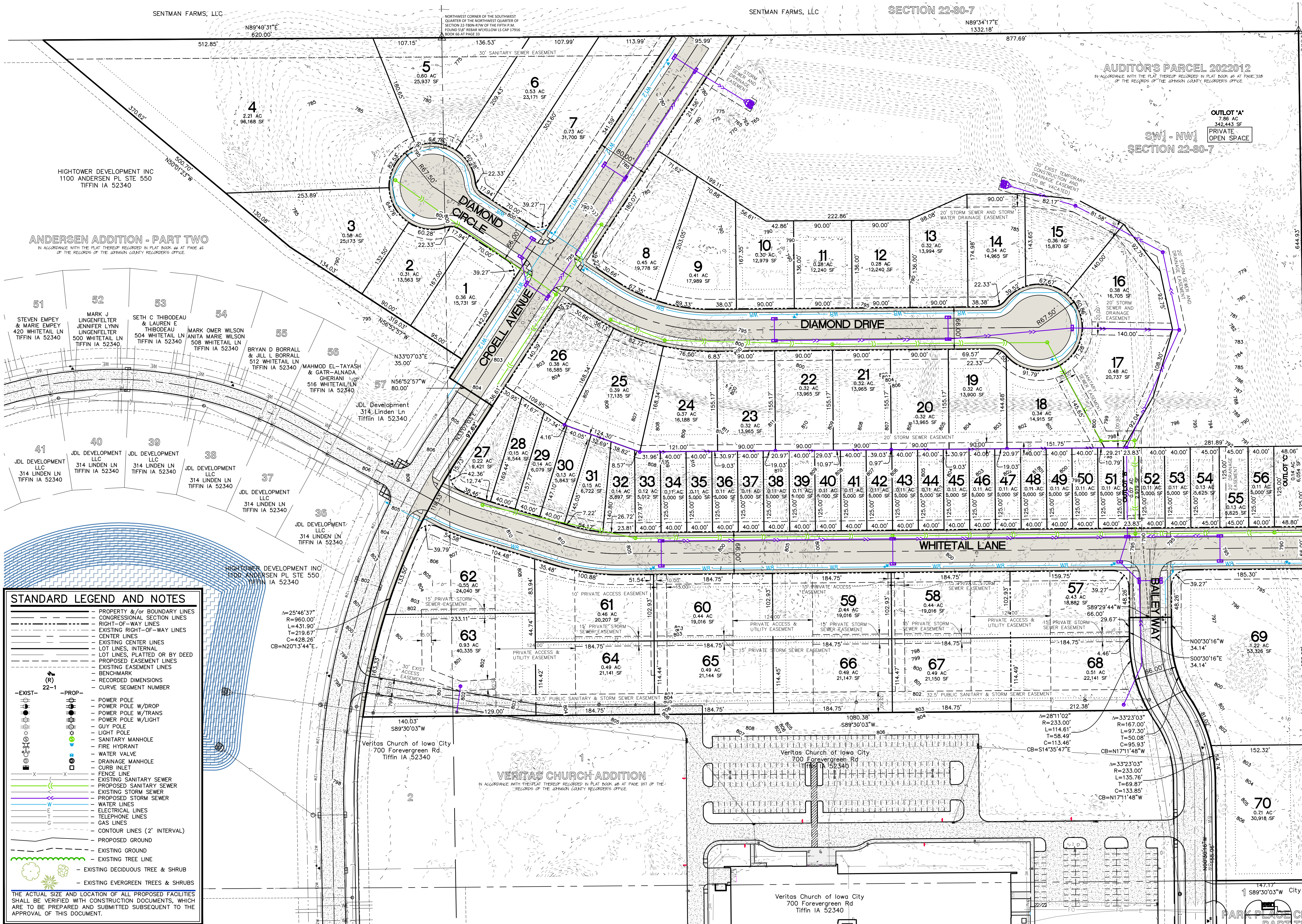
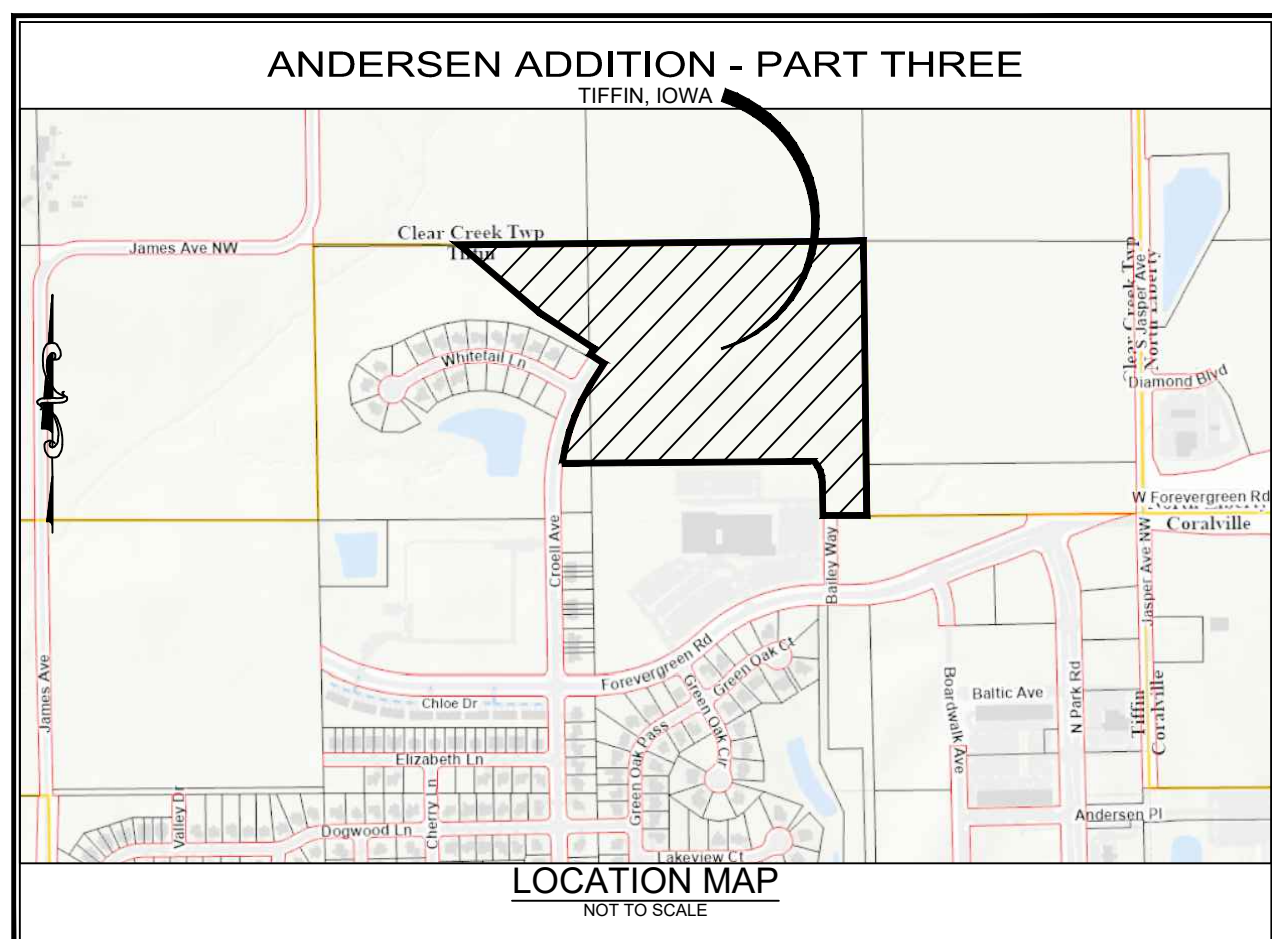
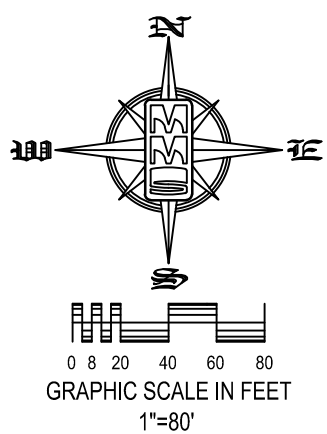

STANDARD LEGEND AND NOTES. Lists symbols for property boundaries, easements, utility lines, and other features.

RESOLUTION NO. 2026-033

A RESOLUTION APPROVING THE THIRD AMENDMENT TO SUBDIVIDER'S AGREEMENT FOR ANDERSEN ADDITION – PART THREE

Whereas, MMS Consultants, on behalf of Hightower Development, Inc., has filed with the City of Tiffin a preliminary plat for Andersen Addition – part three, a subdivision to the City of Tiffin, Iowa; and,

Whereas, the subdivision required a third amended subdivider's agreement with the attached changes; and,

Whereas, the amended Subdivider's Agreement will include any and all particulars to the proposed preliminary plat for Andersen Addition,

Now, therefore be it resolved by the City Council of the City of Tiffin, Iowa, that the Attorneys representing Hightower Development/Andersen Addition and the City of Tiffin have reviewed and have taken under consideration all requested revisions. The City Council now having further reviewed the amended Subdivider's Agreement and do now approve the Agreement as printed and authorize the Mayor and City Clerk to enter into an agreement with Hightower Development/Andersen Addition – Part Three, to fully execute the document.

On the 5th day of May, 2026, at a regular meeting of the Tiffin City Council, Tiffin, Iowa, Councilperson _____ introduced **RESOLUTION NO. 2026-033, A RESOLUTION APPROVING THE THIRD AMENDMENT TO SUBDIVIDER'S AGREEMENT FOR ANDERSEN ADDITION – PART THREE** and made a motion for approval. Motion seconded by Councilperson _____.

Ayes:

Nays:

Whereupon _____ Council members were present and voted approval and Mayor Kasperek declared that **RESOLUTION NO. 2026-033, A RESOLUTION APPROVING THE THIRD AMENDMENT TO SUBDIVIDER'S AGREEMENT FOR ANDERSEN ADDITION – PART THREE** to be adopted and signified his approval of the same by affixing his signature thereto.

Passed by the City Council on the 5th day of May, 2026.

City of Tiffin

Tim Kasperek, Mayor

ATTEST: _____
Abigail Hora, City Clerk

Prepared by and after recording return to:

Matthew J. Hektoen 115 Third Street SE, Suite 1200 (319) 366-7641
Simmons Perrine Moyer Bergman PLLC Cedar Rapids, Iowa facsimile (319) 366-1917

THIRD AMENDMENT
TO
ANDERSEN ADDITION SUBDIVIDER'S AGREEMENT

THIS SECOND AMENDMENT TO SUBDIVIDER'S AGREEMENT (this "*Amendment*"), is made and entered into by and between the City of Tiffin, Iowa, a municipal corporation (the "*City*") and Hightower Development, Inc., an Iowa corporation ("*Subdivider*").

RECITALS

- A. WHEREAS, the City and the Subdivider are parties to that certain Andersen Addition Subdivider's Agreement filed July 19, 2019 in Book 5931 Page 904 in the records of the Johnson County, Iowa Recorder.
- B. WHEREAS, the City and the Subdivider executed a First Amendment to Subdivider's Agreement which was filed on January 24, 2022 in Book 6337, Page 209 in the records of the Johnson County, Iowa Recorder.
- C. WHEREAS, the City and the Subdivider executed a Second Amendment to Subdivider's Agreement which was filed on October 7, 2022 in Book 6432, Page 207 in the records of the Johnson County, Iowa Recorder
- D. WHEREAS, the City and the Subdivider desire to further amend the Agreement.

NOW, THEREFORE, the parties hereby agree as follows:

1. **Amendments to Section 3 of the Subdivider’s Agreement, as amended**

- a. Section 3(C)(4) is of the Agreement is hereby amended to add: The Developer shall construct the sidewalk on Croell Avenue abutting Outlot A Andersen Addition – Part Three, and the sidewalks on Whitetail Lane abutting Outlot B and Outlot C Andersen Addition – Part Three, all prior to final plat approval.
- b. Section 3(C)(5) is of the Agreement is hereby amended to (i) strike the words “and Lot 58” and (ii) replace “Outlot D” with “Outlot A of Andersen Addition – Part Three.”
- c. Section 3(C)(9) is of the Agreement is hereby amended to replace “Outlot D” with “Outlot A of Andersen Addition – Part Three.”
- d. A new Section 3(C)(10) is added to the Agreement as follows: Outlot B of Andersen Addition – Part Three shall be private open space and subject to any easements granted to the City.

e. The final sentence of Section 3(G) of the Agreement, which currently states: “The cost due from the Subdivider for this upgrade is \$616.67/acre for 55.41 acres for a total of \$34,169.68, which shall be prorated across Lots 2-5, inclusive, Lots 36-57, inclusive, Lots 58 – 68, inclusive, and the prorated amount shall be paid prior to final plat approval for any given Part.”

is hereby amended to state as follows:

“The cost due from the Subdivider for this upgrade is \$616.67/acre for 55.41 acres for a total of \$34,169.68, which shall be prorated across Lots 2-5 (Part Two), inclusive, Lots 36-57 (Part Two), inclusive, Lots 1-70 (Part Three), inclusive, and the prorated amount shall be paid prior to final plat approval for any given Part. The upgrade fee for Part Two has been paid.”

- f. The approved preliminary plat for Andersen Addition – Part Three is attached as Exhibit A.

2. **Additional Requirements for Lots 27-56, inclusive, Andersen Addition Part Three, known as “Lotus Hill North OPD.”**

- a. The Lotus Hill North OPD (“OPD”) shall be developed according to the Site Plan (attached as Exhibit B) and preliminary plat as approved by the City and according to the plans and specifications as approved by the City. All construction plans shall be approved before the commencement of any work in accordance with the Site Plan and preliminary plat. There shall be no variance from the approved preliminary plat, approved Site Plan, or from the construction plans and specifications, unless approved in writing by the City.

- b. All landscaping shall be installed and maintained perpetually by the Developer, in accordance with the landscape plan set forth in the Site Plan. If the Developer, or its assigns fails to maintain the landscaping in accordance with the approved OPD, the City shall have the right, after 30 days' notice, to take any and all necessary actions to bring the Site's landscaping into compliance. The costs of such action shall be assessed to the property and need not meet the requirements of notice, benefit or value as provided by the Code of Iowa for assessments.
 - c. Construction of the public improvements must commence within two (2) years from the date of City approval of OPD Site District, or the approval of the OPD Site District shall be null and void without any action by the City Council.
 - d. All OPD lots shall be detached single family.
 - e. The main level of a building on each OPD lot shall be ADA adaptable.
- 3. Counterparts. This Amendment may be executed in counterparts, each of which shall be deemed an original but all of which shall constitute one and the same instrument.
 - 4. No Effect. Except for the terms and conditions of the Subdivider's Agreement amended hereby all remaining terms and conditions remain in full force and effect.
 - 5. PDF and Electronic Signatures. This Amendment may be signed by faxed, emailed or other electronic signatures (e.g. DocuSign) and faxed, emailed or such other electronic signatures hereon shall be deemed originals for all purposes.

[Signature Page Follows]

[Signature Page to Third Amendment to Subdivider's Agreement]

HIGHTOWER DEVELOPMENT, INC.

By: _____
Name: Scott Andersen
Title: President

STATE OF IOWA)
) ss:
COUNTY OF JOHNSON)

This instrument was acknowledged before me on _____ ____, 2026 by Scott Andersen, President of Hightower Development, Inc.

Notary Public - State of Iowa
My Commission Expires: _____

CITY OF TIFFIN, IOWA

ATTEST

By: _____
Tim Kasperek, Mayor

Abigail Hora, City Clerk

STATE OF IOWA)
)ss.
COUNTY OF JOHNSON)

On this ____ day of _____, 2026, before me, a notary public in and for said county, personally appeared Tim Kasperek and Abigail Hora, as Mayor and City Clerk, respectively, of the City of Tiffin, Iowa.

NOTARY PUBLIC IN AND FOR IOWA
My commission expires:



TIFFIN, IA

Expense Approval Report

By Fund

Payable Dates 5/5/2026 - 5/5/2026

Vendor Name	Payable Number	Post Date	Description (Item)	Account Number	Amount
Fund: 001 - General Fund					
HARRYS CUSTOM TROPHIES	008216	05/05/2026	EMPLOYEE APPRECIATION PL	001-610-6297	233.24
HARRYS CUSTOM TROPHIES	008233	05/05/2026	NAME PLATE	001-650-6506	11.26
JOHN DEERE FINANCIAL	05052026	05/05/2026	TOOLS, SUPPLIES, OIL, BOOTS	001-430-6320	39.96
JOHN DEERE FINANCIAL	05052026	05/05/2026	TOOLS, SUPPLIES, OIL, BOOTS	001-430-6332	187.90
JOHN DEERE FINANCIAL	05052026	05/05/2026	TOOLS, SUPPLIES, OIL, BOOTS	001-430-6332	109.96
JOHN DEERE FINANCIAL	05052026	05/05/2026	TOOLS, SUPPLIES, OIL, BOOTS	001-430-6332	27.99
JOHN DEERE FINANCIAL	05052026	05/05/2026	TOOLS, SUPPLIES, OIL, BOOTS	001-430-6332	25.98
JOHN DEERE FINANCIAL	05052026	05/05/2026	TOOLS, SUPPLIES, OIL, BOOTS	001-430-6507	19.98
PITNEY BOWES BANK INC RES	05052026	05/05/2026	POSTAGE	001-650-6508	400.00
BANACOM SIGNS & MORE	10149	05/05/2026	MOBILE FOOD VENDOR STICK	001-150-6250	70.20
THE GAZETTE	12026.00002476	05/05/2026	PRINTING/PUBLISHING 3-25	001-640-6414	95.82
THE GAZETTE	12026.00002512	05/05/2026	PRINTING/PUBLISHING 4-3 MI	001-640-6414	79.41
THE GAZETTE	12026.00002592	05/05/2026	PRINTING/PUBLISHING BUDG	001-640-6414	151.59
THE GAZETTE	12026.00002607	05/05/2026	PRINTING/PUBLISHING REZO	001-640-6414	28.22
THE GAZETTE	12026.00002608	05/05/2026	PRINTING/PUBLISHING 4-3 MI	001-640-6414	82.04
THE GAZETTE	12026.00002609	05/05/2026	PRINTING/PUBLISHING 4-7 MI	001-640-6414	564.42
AMAZON CAPITAL SERVICES	16WF-G9MW-JRK1 (2)	05/05/2026	OFFICE SUPPLIES, TOOLS, BO	001-410-6507	347.94
AMAZON CAPITAL SERVICES	16WF-G9MW-JRK1 (2)	05/05/2026	OFFICE SUPPLIES, TOOLS, BO	001-430-6504	15.29
AMAZON CAPITAL SERVICES	16WF-G9MW-JRK1 (2)	05/05/2026	OFFICE SUPPLIES, TOOLS, BO	001-430-6507	14.69
AMAZON CAPITAL SERVICES	16WF-G9MW-JRK1 (2)	05/05/2026	OFFICE SUPPLIES, TOOLS, BO	001-431-4760	63.95
AMAZON CAPITAL SERVICES	16WF-G9MW-JRK1 (2)	05/05/2026	OFFICE SUPPLIES, TOOLS, BO	001-431-4760	53.93
AMAZON CAPITAL SERVICES	16WF-G9MW-JRK1 (2)	05/05/2026	OFFICE SUPPLIES, TOOLS, BO	001-431-6597	101.85
AMAZON CAPITAL SERVICES	16WF-G9MW-JRK1 (2)	05/05/2026	OFFICE SUPPLIES, TOOLS, BO	001-650-6506	19.84
AMAZON CAPITAL SERVICES	16WF-G9MW-JRK1 (2)	05/05/2026	OFFICE SUPPLIES, TOOLS, BO	001-650-6506	20.22
AMAZON CAPITAL SERVICES	16WF-G9MW-JRK1 (2)	05/05/2026	OFFICE SUPPLIES, TOOLS, BO	001-650-6506	24.98
AMAZON CAPITAL SERVICES	16WF-G9MW-JRK1 (2)	05/05/2026	OFFICE SUPPLIES, TOOLS, BO	001-650-6506	45.94
AMAZON CAPITAL SERVICES	16WF-G9MW-JRK1 (2)	05/05/2026	OFFICE SUPPLIES, TOOLS, BO	001-650-6506	58.99
HALF MOON LANDSCAPING	1768	05/05/2026	FIELDS & DOG PARK OVERSEE	001-430-6320	6,465.00
FIRE CATT, LLC	17769	05/05/2026	FIRE HOSE TESTING	001-150-6350	4,494.00
ALLIANT ENERGY	31399-O-1371	05/05/2026	ELEC. - STREET LIGHTS, TRAFFI	001-150-6371	453.07
ALLIANT ENERGY	31399-O-1371	05/05/2026	ELEC. - STREET LIGHTS, TRAFFI	001-199-6371	143.10
ALLIANT ENERGY	31399-O-1371	05/05/2026	ELEC. - STREET LIGHTS, TRAFFI	001-430-6371	913.61
ALLIANT ENERGY	31399-O-1371	05/05/2026	ELEC. - STREET LIGHTS, TRAFFI	001-650-6371	171.80
PITNEY BOWES GLOBAL FINA	3322472512	05/05/2026	FOLDER/INSERTER, MAIL CEN	001-650-6508	425.71
NEUMILLER ELECTRIC INC.	34428	05/05/2026	VB COURT LIGHTING	001-430-6710	7,800.00
US FOODS, INC IOWA	3614336	05/05/2026	CONCESSIONS SUPPLIES	001-431-6597	198.93
JUNGE	3682430/1	05/05/2026	2020 FORD SUPER DUTY OIL C	001-150-6332	64.46
US FOODS, INC IOWA	3817707	05/05/2026	CONCESSION STAND FOOD	001-431-6597	2,012.67
TNT LANDSCAPING LLC	45104	05/05/2026	DUAL WHEEL TOOL	001-430-6350	145.00
WALKER WELDING	5024	05/05/2026	SHOP LABOR	001-430-6504	298.75
AGVANTAGE FS	69022521	05/05/2026	FUEL	001-150-6331	256.02
AGVANTAGE FS	69022521	05/05/2026	FUEL	001-170-6331	112.66
AGVANTAGE FS	69022521	05/05/2026	FUEL	001-430-6512	40.96
NATIONWIDE OFFICE CLEANE	71995	05/05/2026	CITY HALL/PW CLEANING	001-650-6409	405.29
IOWA INTERSTATE RAILROAD,	735274	05/05/2026	MEHMEN AVE SIGNAL MAINT	001-210-6417	846.36
ALPHAGRAPHICS OF NORTH L	74800	05/05/2026	THANK YOU CARDS	001-650-6506	96.71
PEPSICO	78783903	05/05/2026	CONCESSIONS BEVERAGES	001-431-6597	408.82
BOUND TREE	86165682	05/05/2026	EMS SUPPLIES	001-160-6350	12.59
MENARDS	90188	05/05/2026	CONDUIT, TOOL SET	001-430-6507	168.21
RELION INSURANCE SOLUTIO	92553	05/05/2026	FLOOD DEDUCTABLE BUY DO	001-660-6408	4,753.57
MES SERVICE COMPANY LLC	IN2482678	05/05/2026	COMPRESSOR ANNUAL SERVI	001-150-6350	1,472.94
ACCESS SYSTEMS	INV1976530	05/05/2026	NEW PHONE SYSTEM	001-150-6419	398.25
ACCESS SYSTEMS	INV1976530	05/05/2026	NEW PHONE SYSTEM	001-170-6419	398.25

Expense Approval Report

Payable Dates: 5/5/2026 - 5/5/2026

Vendor Name	Payable Number	Post Date	Description (Item)	Account Number	Amount
ACCESS SYSTEMS	INV1976530	05/05/2026	NEW PHONE SYSTEM	001-431-6419	398.25
ACCESS SYSTEMS	INV1976530	05/05/2026	NEW PHONE SYSTEM	001-620-6419	3,186.00
DAKOTA SUPPLY GROUP	S105545234.001	05/05/2026	DEER VIEW RESTROOMS	001-430-6783	2,108.40
CCL SUPPLY, LLC	SO041723	05/05/2026	BRAKE WASH, CLEANER, BUG	001-430-6507	469.23
Fund 001 - General Fund Total:					42,014.20
Fund: 110 - Road Use Tax					
NIPPON SANZO MATHESON I	0033170002	05/05/2026	ACETYLENE, WELDING MIX, O	110-210-6507	145.01
JOHN DEERE FINANCIAL	05052026	05/05/2026	TOOLS, SUPPLIES, OIL, BOOTS	110-210-6181	233.97
JOHN DEERE FINANCIAL	05052026	05/05/2026	TOOLS, SUPPLIES, OIL, BOOTS	110-210-6504	9.13
JOHN DEERE FINANCIAL	05052026	05/05/2026	TOOLS, SUPPLIES, OIL, BOOTS	110-210-6504	15.66
JOHN DEERE FINANCIAL	05052026	05/05/2026	TOOLS, SUPPLIES, OIL, BOOTS	110-210-6504	50.43
JOHN DEERE FINANCIAL	05052026	05/05/2026	TOOLS, SUPPLIES, OIL, BOOTS	110-210-6507	49.96
JOHN DEERE FINANCIAL	05052026	05/05/2026	TOOLS, SUPPLIES, OIL, BOOTS	110-210-6507	31.77
JOHN DEERE FINANCIAL	05052026	05/05/2026	TOOLS, SUPPLIES, OIL, BOOTS	110-210-6507	19.98
LL PELLING	133043	05/05/2026	HOTMIX	110-210-6417	227.91
AMAZON CAPITAL SERVICES	16WF-G9MW-JRK1 (2)	05/05/2026	OFFICE SUPPLIES, TOOLS, BO	110-210-6504	15.29
AMAZON CAPITAL SERVICES	16WF-G9MW-JRK1 (2)	05/05/2026	OFFICE SUPPLIES, TOOLS, BO	110-210-6509	286.00
IOWA PRISON INDUSTRIES	305249	05/05/2026	SIGNS	110-210-6509	286.00
IOWA PRISON INDUSTRIES	305252	05/05/2026	SIGNS	110-210-6509	119.00
IOWA PRISON INDUSTRIES	305327	05/05/2026	STREET SIGNS	110-210-6509	1,894.00
IOWA PRISON INDUSTRIES	305340	05/05/2026	SIGNS	110-210-6509	68.10
ALLIANT ENERGY	31399-O-1371	05/05/2026	ELEC. - STREET LIGHTS, TRAFFI	110-210-6371	827.83
ALLIANT ENERGY	31399-O-1371	05/05/2026	ELEC. - STREET LIGHTS, TRAFFI	110-230-6371	5,305.03
ALLIANT ENERGY	31399-O-1371	05/05/2026	ELEC. - STREET LIGHTS, TRAFFI	110-240-6371	160.69
NEUMILLER ELECTRIC INC.	34375	05/05/2026	STREET LIGHT REPAIR 2ND ST/	110-230-6371	265.00
WALKER WELDING	5024	05/05/2026	SHOP LABOR	110-210-6504	298.74
AGVANTAGE FS	69022521	05/05/2026	FUEL	110-210-6512	512.04
NATIONWIDE OFFICE CLEANE	71995	05/05/2026	CITY HALL/PW CLEANING	110-210-6409	405.29
ACCESS SYSTEMS	INV1976530	05/05/2026	NEW PHONE SYSTEM	110-210-6419	398.25
CCL SUPPLY, LLC	SO041723	05/05/2026	BRAKE WASH, CLEANER, BUG	110-210-6507	469.22
Fund 110 - Road Use Tax Total:					12,094.30
Fund: 307 - Park Road Paving					
BOOMERANG CORP.	PAY REQUEST 12	05/05/2026	N PARK RD WIDENING	307-210-6499	357,065.04
Fund 307 - Park Road Paving Total:					357,065.04
Fund: 309 - US HWY 6 RECONSTRUCTION					
MSA PROFESSIONAL SERVICES	028067	05/05/2026	HWY 6 RECONSTRUCTION	309-210-6407	35,614.50
Fund 309 - US HWY 6 RECONSTRUCTION Total:					35,614.50
Fund: 339 - Original Town PH3					
HART FREDERICK CONSULTAN	26-03065	05/05/2026	ORIG TOWN URBANIZATION P	339-210-6407	3,450.00
HART FREDERICK CONSULTAN	26-03066	05/05/2026	ORIG TOWN URBANIZATION P	339-210-6407	4,465.00
Fund 339 - Original Town PH3 Total:					7,915.00
Fund: 340 - Recreation Center					
S&P GLOBAL RATINGS	11513380	05/05/2026	S&P RATING 2026A BOND	340-430-6499	22,990.00
ATURA ARCHITECTURE	202311100022	05/05/2026	CONSTRUCTION ADMIN	340-430-6407	6,812.00
Fund 340 - Recreation Center Total:					29,802.00
Fund: 600 - Water					
MEDIACOM	05052026	05/05/2026	INTERNET FOR WWTP	600-810-6373	151.97
JOHN DEERE FINANCIAL	05052026	05/05/2026	TOOLS, SUPPLIES, OIL, BOOTS	600-810-6504	2.99
JOHN DEERE FINANCIAL	05052026	05/05/2026	TOOLS, SUPPLIES, OIL, BOOTS	600-810-6504	9.17
PITNEY BOWES BANK INC RES	05052026	05/05/2026	POSTAGE	600-810-6508	800.00
CHEM-SULT INC	16290	05/05/2026	CHEMICALS	600-810-6501	2,016.05
AMAZON CAPITAL SERVICES	16WF-G9MW-JRK1 (2)	05/05/2026	OFFICE SUPPLIES, TOOLS, BO	600-810-6350	11.19
AMAZON CAPITAL SERVICES	16WF-G9MW-JRK1 (2)	05/05/2026	OFFICE SUPPLIES, TOOLS, BO	600-810-6350	9.89
AMAZON CAPITAL SERVICES	16WF-G9MW-JRK1 (2)	05/05/2026	OFFICE SUPPLIES, TOOLS, BO	600-810-6350	22.67
AMAZON CAPITAL SERVICES	16WF-G9MW-JRK1 (2)	05/05/2026	OFFICE SUPPLIES, TOOLS, BO	600-810-6350	74.88
AMAZON CAPITAL SERVICES	16WF-G9MW-JRK1 (2)	05/05/2026	OFFICE SUPPLIES, TOOLS, BO	600-810-6350	18.89
AMAZON CAPITAL SERVICES	16WF-G9MW-JRK1 (2)	05/05/2026	OFFICE SUPPLIES, TOOLS, BO	600-810-6350	18.22
AMAZON CAPITAL SERVICES	16WF-G9MW-JRK1 (2)	05/05/2026	OFFICE SUPPLIES, TOOLS, BO	600-810-6350	32.55

Expense Approval Report

Payable Dates: 5/5/2026 - 5/5/2026

Vendor Name	Payable Number	Post Date	Description (Item)	Account Number	Amount
AMAZON CAPITAL SERVICES	16WF-G9MW-JRK1 (2)	05/05/2026	OFFICE SUPPLIES, TOOLS, BO	600-810-6504	21.36
AMAZON CAPITAL SERVICES	16WF-G9MW-JRK1 (2)	05/05/2026	OFFICE SUPPLIES, TOOLS, BO	600-810-6504	35.99
AMAZON CAPITAL SERVICES	16WF-G9MW-JRK1 (2)	05/05/2026	OFFICE SUPPLIES, TOOLS, BO	600-810-6504	28.99
CARGILL INC	2912316074	05/05/2026	SALT FOR WATER PLANT	600-810-6501	6,059.63
ALLIANT ENERGY	31399-O-1371	05/05/2026	ELEC. - STREET LIGHTS, TRAFFI	600-810-6371	15,260.84
PITNEY BOWES GLOBAL FINA	3322472512	05/05/2026	FOLDER/INSERTER, MAIL CEN	600-810-6508	851.41
CRYSTAL CLEAR WATER CO	560546	05/05/2026	WATER & SEWER TESTING SU	600-810-6511	31.20
AGVANTAGE FS	69022521	05/05/2026	FUEL	600-810-6512	51.20
RELION INSURANCE SOLUTIO	92553	05/05/2026	FLOOD DEDUCTABLE BUY DO	600-810-6408	1,584.52
ACCESS SYSTEMS	INV1976530	05/05/2026	NEW PHONE SYSTEM	600-810-6419	1,593.00
Fund 600 - Water Total:					28,686.61

Fund: 608 - WATER TREATMENT PLANT

MSA PROFESSIONAL SERVICES	028435	05/05/2026	WATER TREATMENT FACILITY	608-810-6407	32,283.66
TRICON CONSTRUCTION GRO	PAY APPLICATION 8	05/05/2026	WATER TREATMENT PLANT	608-810-6499	1,178,412.67
Fund 608 - WATER TREATMENT PLANT Total:					1,210,696.33

Fund: 610 - Sewer

MSA PROFESSIONAL SERVICES	028283	05/05/2026	SANITARY SEWER STUDY	610-815-6490	2,149.50
AUTOMATIC SYSTEMS	044940	05/05/2026	WIN911 DOWN	610-815-6490	756.25
AUTOMATIC SYSTEMS	044968	05/05/2026	PARK RD LIFT STATION	610-815-6490	1,715.00
AUTOMATIC SYSTEMS	044977	05/05/2026	DOT LIFT STATION TRANSDUC	610-815-6350	2,885.80
MEDIACOM	05052026	05/05/2026	INTERNET FOR WWTP	610-815-6371	151.97
JOHN DEERE FINANCIAL	05052026	05/05/2026	TOOLS, SUPPLIES, OIL, BOOTS	610-815-6504	1.29
PITNEY BOWES BANK INC RES	05052026	05/05/2026	POSTAGE	610-815-6508	800.00
AMAZON CAPITAL SERVICES	16WF-G9MW-JRK1 (2)	05/05/2026	OFFICE SUPPLIES, TOOLS, BO	610-815-6504	28.99
AMAZON CAPITAL SERVICES	16WF-G9MW-JRK1 (2)	05/05/2026	OFFICE SUPPLIES, TOOLS, BO	610-815-6504	35.36
AMAZON CAPITAL SERVICES	16WF-G9MW-JRK1 (2)	05/05/2026	OFFICE SUPPLIES, TOOLS, BO	610-815-6504	58.46
AMAZON CAPITAL SERVICES	16WF-G9MW-JRK1 (2)	05/05/2026	OFFICE SUPPLIES, TOOLS, BO	610-815-6504	14.18
AMAZON CAPITAL SERVICES	16WF-G9MW-JRK1 (2)	05/05/2026	OFFICE SUPPLIES, TOOLS, BO	610-815-6506	276.35
SMITH SANITATION	260413064044	05/05/2026	WW PLANT DUMPSTER RENT	610-815-6490	175.00
ALLIANT ENERGY	31399-O-1371	05/05/2026	ELEC. - STREET LIGHTS, TRAFFI	610-815-6371	7,599.65
PITNEY BOWES GLOBAL FINA	3322472512	05/05/2026	FOLDER/INSERTER, MAIL CEN	610-815-6508	851.41
STEVE'S ELECTRIC	3682	05/05/2026	WASTEWATER RELAY REPLACE	610-815-6490	150.00
CRYSTAL CLEAR WATER CO	560546	05/05/2026	WATER & SEWER TESTING SU	610-815-6511	31.20
AGVANTAGE FS	69022521	05/05/2026	FUEL	610-815-6512	51.20
APPLIED INDUSTRIAL TECHNO	7034365102	05/05/2026	SHOCK RELAY	610-815-6350	466.50
HAWKINS, INC	7405059	05/05/2026	CHEMICALS	610-815-6501	1,249.00
RELION INSURANCE SOLUTIO	92553	05/05/2026	FLOOD DEDUCTABLE BUY DO	610-815-6408	1,584.52
MIDWEST PUMP WORKS	INV030525	05/05/2026	MOTOR REPAIR	610-815-6350	458.65
MIDWEST PUMP WORKS	INV030526	05/05/2026	BREAKER TRIPPING, GRINDER	610-815-6490	1,289.70
ACCESS SYSTEMS	INV1976530	05/05/2026	NEW PHONE SYSTEM	610-815-6419	1,593.00
Fund 610 - Sewer Total:					24,372.98

Grand Total: 1,748,260.96

Report Summary

Fund Summary

Fund	Payment Amount
001 - General Fund	42,014.20
110 - Road Use Tax	12,094.30
307 - Park Road Paving	357,065.04
309 - US HWY 6 RECONSTRUCTION	35,614.50
339 - Original Town PH3	7,915.00
340 - Recreation Center	29,802.00
600 - Water	28,686.61
608 - WATER TREATMENT PLANT	1,210,696.33
610 - Sewer	24,372.98
Grand Total:	1,748,260.96

Account Summary

Account Number	Account Name	Payment Amount
001-150-6250	COMMUNITY RISK REDU	70.20
001-150-6331	FUEL - FIRE	256.02
001-150-6332	VEHICLE REPAIRS - FIRE	64.46
001-150-6350	OPERATIONAL EQUIPME	5,966.94
001-150-6371	UTILITIES- FIRE	453.07
001-150-6419	TECHNOLOGY SERVICES-	398.25
001-160-6350	SUPPLIES - EMS	12.59
001-170-6331	FUEL - BUILDING	112.66
001-170-6419	TECHNOLOGY SERVICES-	398.25
001-199-6371	UTILITIES-WARNING SIR	143.10
001-210-6417	RAILROAD CROSSING M	846.36
001-410-6507	OPERATING SUPPLIES - L	347.94
001-430-6320	GROUNDS REPAIR/MAIN	6,504.96
001-430-6332	VEHICLE REPAIRS - PARK	351.83
001-430-6350	OPER EQUIP REPAIR - PA	145.00
001-430-6371	UTILITIES-PARKS	913.61
001-430-6504	MINOR EQUIPMENT - PA	314.04
001-430-6507	OPERATING SUPPLIES - P	672.11
001-430-6512	VEHICLE/EQUIPMENT F	40.96
001-430-6710	CAP OUTLAY	7,800.00
001-430-6783	CITY PARK IMPROVEME	2,108.40
001-431-4760	CONCESSIONS - RECREA	117.88
001-431-6419	TECHNOLOGY SERVICES-	398.25
001-431-6597	CONCESSIONS SUPPLIES	2,722.27
001-610-6297	PUBLIC EXP RECG (POLIC	233.24
001-620-6419	TECHNOLOGY SERVICES	3,186.00
001-640-6414	PRINTING/PUBLISHING	1,001.50
001-650-6371	UTILITIES-CITY HALL	171.80
001-650-6409	CITY HALL CLEANING	405.29
001-650-6506	OFFICE SUPPLIES	277.94
001-650-6508	POSTAGE	825.71
001-660-6408	INSURANCE-PROPERTY I	4,753.57
110-210-6181	UNIFORM ALLOWANCE -	233.97
110-210-6371	UTILITIES - RUT STREETS	827.83
110-210-6409	PUBLIC WORKS CLEANIN	405.29
110-210-6417	STREET MAINTENANCE -	227.91
110-210-6419	TECHNOLOGY SERVICES-	398.25
110-210-6504	MINOR EQUIPMENT - R	389.25
110-210-6507	OPERATING SUPPLIES -R	715.94
110-210-6509	POSTS/SIGNS - RUT STRE	2,653.10
110-210-6512	VEHICLE/EQUIPMENT F	512.04
110-230-6371	STREET LIGHTS - UTILITY	5,570.03
110-240-6371	TRAFFIC SIGNALS - UTILI	160.69
307-210-6499	CONTRACTUAL - NORTH	357,065.04

Account Summary

Account Number	Account Name	Payment Amount
309-210-6407	ENGINEERING - US HWY	35,614.50
339-210-6407	ENGINEERING- ORIGINA	7,915.00
340-430-6407	ENGINEERING- RECREATI	6,812.00
340-430-6499	CONTRACTURAL - RECRE	22,990.00
600-810-6350	OPERATIONAL EQUIP RE	188.29
600-810-6371	UTILITIES - WATER	15,260.84
600-810-6373	TELEPHONE/COMM-WA	151.97
600-810-6408	INSURANCE-PROPERTY I	1,584.52
600-810-6419	TECHNOLOGY SERVICES	1,593.00
600-810-6501	CHEMICALS	8,075.68
600-810-6504	MINOR EQUIPMENT	98.50
600-810-6508	POSTAGE	1,651.41
600-810-6511	WATER TESTING SUPPLIE	31.20
600-810-6512	VEHICLE/EQUIPMENT F	51.20
608-810-6407	ENGINEERING - WATER T	32,283.66
608-810-6499	CONTRACTUAL - WATER	1,178,412.67
610-815-6350	OPERATIONAL EQUIP RE	3,810.95
610-815-6371	UTILITIES - SEWER	7,751.62
610-815-6408	INSURANCE-PROPERTY I	1,584.52
610-815-6419	TECHNOLOGY SERVICES	1,593.00
610-815-6490	OTHER PROFESSIONAL S	6,235.45
610-815-6501	CHEMICALS	1,249.00
610-815-6504	MINOR EQUIPMENT	138.28
610-815-6506	OFFICE SUPPLIES	276.35
610-815-6508	POSTAGE	1,651.41
610-815-6511	SEWER TESTING SUPPLIE	31.20
610-815-6512	VEHICLE/EQUIPMENT F	51.20
	Grand Total:	1,748,260.96

Project Account Summary

Project Account Key	Payment Amount
None	1,748,260.96
Grand Total:	1,748,260.96



**AGENDA INFORMATION
TIFFIN CITY COUNCIL COMMUNICATION**

DATE:	April 2, 2026
AGENDA ITEM:	Discussion and Consideration of Pay Application #8 – Tricon Construction – Water Treatment Plant Upgrades
ACTION:	Motion

Background

The City entered into a construction contract with **Tricon Construction Group** for upgrades to the City’s Water Treatment Plant. The project includes structural, mechanical, piping, and instrumentation improvements intended to enhance system reliability, safety, and long-term operational efficiency.

Pay applications are submitted monthly and reviewed by City staff and the project engineer prior to being presented for Council approval.

Pay Application No. 8 represents progress billing for ongoing construction and materials related to the Water Treatment Plant Upgrades project. The application has been reviewed by staff and the project engineer and reflects acceptable work performed and materials incorporated in accordance with the contract documents.

Pay Application No. 8 covers the application period through **April 24, 2026**, with an application date of **April 30, 2026**. This request includes:

- Stored and incorporated materials associated with clearwell construction
- Mechanical and instrumentation components
- Valves, pumps, slide gates, lab equipment, and plumbing fixtures
- Rebar installation work incorporated into the clearwell structure

The project remains active and is progressing in accordance with the established construction schedule.

City staff and the project engineer have reviewed Pay Application No. 8 and verified that the quantities, costs, and materials are consistent with work completed to date. The application complies with contract terms, and there are no outstanding issues affecting the recommendation for approval.

Staff Recommendation

Staff recommends approval of Pay Application No. 8 to Tricon Construction Group in the amount of \$86,715.70 for the Water Treatment Plant Upgrades project.

ATTACHMENTS: Pay Application

Contractor's Application for Payment

Owner: <u>City of Tiffin</u>	Owner's Project No.: _____
Engineer: <u>MSA Professional Services</u>	Engineer's Project No.: <u>13603016</u>
Contractor: <u>Tricon Construction Group</u>	Contractor's Project No.: _____
Project: <u>Water Treatment Plant Upgrades - City of Tiffin</u>	
Contract: <u>Water Treatment Plant Upgrades</u>	
Application No.: <u>8</u>	Application Date: <u>4/24/2026</u>
Application Period: From <u>3/28/2026</u> to <u>4/23/2026</u>	

1. Original Contract Price	\$	12,182,553.00
2. Net change by Change Orders	\$	12,420.34
3. Current Contract Price (Line 1 + Line 2)	\$	12,194,973.34
4. Total Work completed and materials stored to date	\$	4,101,519.57
(Sum of Column G Lump Sum Total and Column G Unit Price Total)	\$	4,101,519.57
5. Retainage		
a. <u>5%</u> X \$ <u>3,808,393.49</u> Work Completed	\$	190,419.67
b. <u>5%</u> X \$ <u>293,126.08</u> Stored Materials	\$	14,656.30
c. Total Retainage (Line 5.a + Line 5.b)	\$	205,075.97
6. Amount eligible to date (Line 4 - Line 5.c)	\$	3,896,443.60
7. Less previous payments (Line 6 from prior application)	\$	2,718,030.93
8. Amount due this application	\$	1,178,412.67
9. Balance to finish, including retainage (Line 3 - Line 4, plus 5c)	\$	8,298,529.74

Contractor's Certification
 The undersigned Contractor certifies, to the best of its knowledge, the following:

Contractor: Tricon Construction Group
Signature: Mary K. Stone **Date:** 4/29/2026

PAYMENT OF: \$ _____ **1,178,412.67**
 (line 8 or other - attach explanation of the other amount)

<p>Recommended by Engineer</p> <p>By: <u>Clint Wiener</u></p> <p>Title: <u>Senior Project Engineer</u></p> <p>Date: <u>April 29, 2026</u></p>	<p>Approved by Owner</p> <p>By: _____</p> <p>Title: _____</p> <p>Date: _____</p>
<p>Approved by Funding Agency</p> <p>By: _____</p> <p>Title: _____</p>	<p>By: _____</p> <p>Title: _____</p>
<p>Date: _____</p>	<p>Date: _____</p>

Progress Estimate - Lump Sum Work

Contractor's Application for Payment

Owner: <u>City of Tiffin</u>	Owner's Project No.: _____
Engineer: <u>MSA Professional Services</u>	Engineer's Project No.: <u>13603016</u>
Contractor: <u>Tricon Construction Group</u>	Contractor's Project No.: _____
Project: <u>Water Treatment Plant Upgrades - City of Tiffin</u>	
Contract: _____	

Application No.: 8 **Application Period:** **From** 03/28/26 **to** 04/23/26 **Application Date:** 04/24/26

A	B	C	D		F	G	H	I
			(D + E) From Previous Application (\$)	This Period (\$)				
Item No.	Description	Scheduled Value (\$)			Materials Currently Stored (not in D or E) (\$)	Work Completed and Materials Stored to Date (D + E + F) (\$)	% of Scheduled Value (G / C) (%)	Balance to Finish (C - G) (\$)
Original Contract								
00	General Requirements					-		-
01	General Conditions	\$588,953.00	234,461.22	39,076.87		273,538.09	46%	315,414.91
02	Bond/Buider's Risk Insurance	\$199,542.00	199,542.00			199,542.00	100%	-
03	Allowance EP1 - Generator & ATS	\$329,890.00	329,890.00			329,890.00	100%	-
04	Allowance EP2 Electrical Equipment	Line item 167	-			-		-
05	Allowance - Electrical Service	\$5,000.00	-			-	0%	5,000.00
06	Mobilization	\$350,000.00	240,000.00			240,000.00	69%	110,000.00
07	Site Testing	\$53,736.00	13,383.19	1,354.59		14,737.78	27%	38,998.22
08	Traffic Control	\$10,000.00	1,000.00	1,000.00		2,000.00	20%	8,000.00
09	Portable Toilets	\$5,400.00	1,187.20	148.40		1,335.60	25%	4,064.40
10	Dumpster	\$14,600.00	3,000.00	500.00		3,500.00	24%	11,100.00
11	Concrete Washout Pit	\$2,400.00	240.00	240.00		480.00	20%	1,920.00
12	Erosion Control	\$8,250.00	3,500.00			3,500.00	42%	4,750.00
13			-			-		-
14	Existing Conditions		-			-		-
15	Structure Demolition	\$33,445.00	-			-	0%	33,445.00
16			-			-		-
17	Concrete		-			-		-
18	Structure 10 - Existing Building		-			-		-
19	Rebar - Materials	\$54,588.00	-			-	0%	54,588.00
20	Rebar - Labor	\$46,399.80	-			-	0%	46,399.80
21	Concrete - Materials	\$165,884.00	-			-	0%	165,884.00
22	Concrete - Labor	\$91,308.20	-			-	0%	91,308.20
23	Structure 20 - RO Building		-			-		-
24	Rebar - Materials	\$84,556.00	76,100.40			76,100.40	90%	8,455.60

Progress Estimate - Lump Sum Work

Contractor's Application for Payment

Owner: City of Tiffin
 Engineer: MSA Professional Services
 Contractor: Tricon Construction Group
 Project: Water Treatment Plant Upgrades - City of Tiffin
 Contract: _____

Owner's Project No.: _____
 Engineer's Project No.: 13603016
 Contractor's Project No.: _____

Application No.: 8 Application Period: From 03/28/26 to 04/23/26 Application Date: 04/24/26

25	Rebar - Labor	\$71,872.60	64,685.34		64,685.34	90%	7,187.26
26	Base Footings Materials	\$89,665.00	89,665.00		89,665.00	100%	-
27	Base Footings Labor	\$49,315.75	49,315.75		49,315.75	100%	-
28	Wall Footings Materials	\$98,663.00	98,663.00		98,663.00	100%	-
29	Wall Footings Labor	\$54,264.65	54,264.65		54,264.65	100%	-
30	Floor Slab Materials	\$156,442.00	-		-	0%	156,442.00
31	Floor Slab Labor	\$88,874.50	-		-	0%	88,874.50
32	Equipment Pads Materials	\$1,515.00	151.50		151.50	10%	1,363.50
33	Equipment Pads Labor	\$3,451.50	345.15		345.15	10%	3,106.35
34	Precast Concrete Materials	\$575,000.00	12,125.00	505,375.00	517,500.00	90%	57,500.00
35	Precast Concrete Labor	\$204,412.67	-	132,868.24	132,868.24	65%	71,544.43
36	Structure 30- Clearwell		-		-		-
37	Rebar Materials	\$204,551.00	-	132,958.15	132,958.15	65%	71,592.85
38	Rebar labor	\$112,503.05	-	73,126.98	73,126.98	65%	39,376.07
39	Mat Foundation - Materials	\$123,255.00	-	123,255.00	123,255.00	100%	-
40	Mat Foundation - Labor	\$68,450.80	-	68,450.80	68,450.80	100%	-
41	Walls - Materials	\$78,452.00	-	50,993.80	50,993.80	65%	27,458.20
42	Walls - Labor	\$98,065.00	-	53,935.75	53,935.75	55%	44,129.25
43	Elevated Slab - Materials	\$198,553.00	-		-	0%	198,553.00
44	Elevated Slab - Labor	\$109,204.15	-		-	0%	109,204.15
45	Precast Concrete - Materials	\$210,000.00	-		-	0%	210,000.00
46	Precast Concrete - Labor	\$61,058.33	-		-	0%	61,058.33
47			-		-		-
48	Masonry		-		-		-
49	Masonry - Materials	\$15,116.00	-		-	0%	15,116.00
50	Masonry - Labor	\$50,603.00	-		-	0%	50,603.00
51			-		-		-
52	Metals		-		-		-
53	Metal Fabrications - Materials	\$57,200.00	-		-	0%	57,200.00
54	Metal Fabrications - Labor	\$13,556.25	-		-	0%	13,556.25
55	Handrails & Railings Labor	\$5,966.50	-		-	0%	5,966.50

Progress Estimate - Lump Sum Work

Contractor's Application for Payment

Owner: City of Tiffin	Owner's Project No.:
Engineer: MSA Professional Services	Engineer's Project No.: 13603016
Contractor: Tricon Construction Group	Contractor's Project No.:
Project: Water Treatment Plant Upgrades - City of Tiffin	
Contract:	

Application No.: 8 **Application Period:** **From** 03/28/26 **to** 04/23/26 **Application Date:** 04/24/26

Item No.	Description	Amount	Unit	Start	End	Pay	Rate	Total
56	Grating - Labor	\$2,777.25	-			-	0%	2,777.25
57			-			-		-
58	Wood, Plastics and Composites		-			-		-
59	Structure 10 - Existing Building		-			-		-
60	Walls, Headers, Mezz Hardware - M	\$15,568.75	-			-	0%	15,568.75
61	Walls, Headers, Mezz Hardware - L	\$45,669.32	-			-	0%	45,669.32
62	Trusses - Materials	\$15,887.00	-			-	0%	15,887.00
63	Trusses - Labor	\$55,229.36	-			-	0%	55,229.36
64	Structure 20 - RO Building		-			-		-
65	Walls, Headers, Mezz Hardware - M	\$25,568.65	-			-	0%	25,568.65
66	Walls, Headers, Mezz Hardware - L	\$55,565.78	-			-	0%	55,565.78
67	Trusses - Materials	\$33,966.50	-			-	0%	33,966.50
68	Trusses - Labor	\$79,156.72	-			-	0%	79,156.72
69	FRP Grating - Materials	\$32,000.00	-	500.00		500.00	2%	31,500.00
70	FRP Grating - Labor	\$17,836.00	-			-	0%	17,836.00
71	Structural 30 - Clearwell		-			-		-
72	Walls, Headers, Hardware - Materials	\$3,692.40	-			-	0%	3,692.40
73	Walls, Headers, Hardware - Labor	\$18,569.52	-			-	0%	18,569.52
74	Trusses - Materials	\$5,858.50	-			-	0%	5,858.50
75	Trusses - Labor	\$16,979.50	-			-	0%	16,979.50
76			-			-		-
77	Thermal & Moisture Protection		-			-		-
78	Blown Insulation	\$20,001.00	-			-	0%	20,001.00
79	Structure 10 - Existing Building		-			-		-
80	Metal Roofing - Materials	\$11,566.00	-			-	0%	11,566.00
81	Metal Roofing - Labor	\$6,541.50	-			-	0%	6,541.50
82	Preformed Metal Soffit - Materials	\$1,586.00	-			-	0%	1,586.00
83	Preformed Metal Soffit - Labor	\$1,852.50	-			-	0%	1,852.50
84	Gutters & Downspouts - Materials	\$2,500.00	-			-	0%	2,500.00
85	Gutters & Downspouts - Labor	\$3,215.00	-			-	0%	3,215.00
86	Structure 20 - RO Building		-			-		-

Progress Estimate - Lump Sum Work

Contractor's Application for Payment

Owner: <u>City of Tiffin</u>	Owner's Project No.: _____
Engineer: <u>MSA Professional Services</u>	Engineer's Project No.: <u>13603016</u>
Contractor: <u>Tricon Construction Group</u>	Contractor's Project No.: _____
Project: <u>Water Treatment Plant Upgrades - City of Tiffin</u>	
Contract: _____	

Application No.: 8 **Application Period:** **From** 03/28/26 **to** 04/23/26 **Application Date:** 04/24/26

87	Metal Roofing - Materials	\$35,256.00	-		-	0%	35,256.00
88	Metal Roofing - Labor	\$40,587.00	-		-	0%	40,587.00
89	Preformed Metal Soffit - Materials	\$5,877.00	-		-	0%	5,877.00
90	Preformed Metal Soffit - Labor	\$9,992.12	-		-	0%	9,992.12
91	Gutters & Downspouts - Materials	\$5,600.00	-		-	0%	5,600.00
92	Gutters & Downspouts - Labor	\$8,544.32	-		-	0%	8,544.32
93	Structure 30 - Clearwell		-		-		-
94	Metal Roofing - Materials	\$9,442.00	-		-	0%	9,442.00
95	Metal Roofing - Labor	\$11,566.68	-		-	0%	11,566.68
96	Preformed Metal Soffit - Materials	\$3,655.00	-		-	0%	3,655.00
97	Preformed Metal Soffit - Labor	\$6,552.46	-		-	0%	6,552.46
98	Gutters & Downspouts - Materials	\$2,651.00	-		-	0%	2,651.00
99	Gutters & Downspouts - Labor	\$3,215.42	-		-	0%	3,215.42
100	Roof Hatches - Materials	\$6,200.00	-	5,193.00	5,193.00	84%	1,007.00
101			-		-		-
102	Openings		-		-		-
103	HM Frames, Doors & Hardware-Materials	\$53,528.00	-		-	0%	53,528.00
104	HM Frames, Doors & Hardware-Labor	\$6,890.00	-		-	0%	6,890.00
105	Vault Doors - Materials	\$49,611.00	-	21,050.00	21,050.00	42%	28,561.00
106	Vault Doors - Labor	\$3,110.00	-		-	0%	3,110.00
107	Overhead Door	\$43,790.00	-		-	0%	43,790.00
108	Aluminum Windows	\$8,996.00	-		-	0%	8,996.00
109			-		-		-
110	Finishes		-		-		-
111	Resilient Base	\$2,500.00	-		-	0%	2,500.00
112	Epoxy Flooring	\$67,408.00	-		-	0%	67,408.00
113	High Performance Coatings	\$68,724.00	13,314.75		13,314.75	19%	55,409.25
114			-		-		-
115	Specialties		-		-		-
116	Signage	\$450.00	-		-	0%	450.00
117	Metal Lockers	\$7,100.00	-		-	0%	7,100.00

Progress Estimate - Lump Sum Work

Contractor's Application for Payment

Owner: City of Tiffin
 Engineer: MSA Professional Services
 Contractor: Tricon Construction Group
 Project: Water Treatment Plant Upgrades - City of Tiffin
 Contract: _____

Owner's Project No.: _____
 Engineer's Project No.: 13603016
 Contractor's Project No.: _____

Application No.: 8 Application Period: From 03/28/26 to 04/23/26 Application Date: 04/24/26

Item No.	Description	Contract Value	Applied Value	Remaining Value	Applied %	Remaining %
118	Metal Storage Systems	\$6,947.00	-	-	0%	6,947.00
119	Fire Extinguishers	\$854.00	-	-	0%	854.00
120			-	-		-
121	Furnishings		-	-		-
122	Lab Casework	\$18,810.00	-	-	0%	18,810.00
123			-	-		-
124	Plumbing		-	-		-
125	Bldg 20 Trench Drains/UG Plumbing Mat	\$26,000.00	-	21,000.00	81%	5,000.00
126	Bldg 20 Trench Drains/UG Plumbing Labor	\$25,000.00	-	8,000.00	32%	17,000.00
127	Bldg 20 AG Plumbing Materials	\$5,000.00	-	-	0%	5,000.00
128	Bldg 20 AG Plumbing Materials Labor	\$20,000.00	-	-	0%	20,000.00
129	Bldg 20 Plumbing Fixtures	\$15,500.00	-	14,666.58	95%	833.42
130	Bldg 20 AG Plumbing Labor	\$28,000.00	-	-	0%	28,000.00
131	Bldg 10 AG Plumbing Materials	\$5,000.00	-	-	0%	5,000.00
132	Bldg 10 AG Plumbing Labor	\$20,000.00	-	-	0%	20,000.00
133	Insulation	\$5,000.00	-	-	0%	5,000.00
134			-	-		-
135	HVAC/Dehumidifier		-	-		-
136	EF & Destrat	\$37,066.00	-	-	0%	37,066.00
137	EUH	\$9,492.00	-	-	0%	9,492.00
138	GUH	\$3,660.00	-	-	0%	3,660.00
139	LV & Dampers	\$15,828.00	-	-	0%	15,828.00
140	Split & F/CU	\$20,788.00	-	-	0%	20,788.00
141	Dehumidifiers	\$18,166.00	-	-	0%	18,166.00
142	Duct Material	\$4,003.00	-	-	0%	4,003.00
143	HVAC Materials	\$4,497.00	-	-	0%	4,497.00
144	HVAC Labor	\$117,908.00	-	-	0%	117,908.00
145	Insulation	\$10,000.00	-	-	0%	10,000.00
146	Test & Balance	\$5,750.00	-	-	0%	5,750.00
147			-	-		-
148	Electrical & Controls		-	-		-

Progress Estimate - Lump Sum Work

Contractor's Application for Payment

Owner:	City of Tiffin	Owner's Project No.:	
Engineer:	MSA Professional Services	Engineer's Project No.:	13603016
Contractor:	Tricon Construction Group	Contractor's Project No.:	
Project:	Water Treatment Plant Upgrades - City of Tiffin		
Contract:			

Application No.: 8 **Application Period:** **From** 03/28/26 **to** 04/23/26 **Application Date:** 04/24/26

Item No.	Description	Contract Value	Estimated Value	Actual Value	Percentage	Balance
149	Electrical		-			-
150	Mobilization - Neumiller	\$122,150.00	84,825.00		69%	37,325.00
151	Submittals	\$15,114.00	15,114.00		100%	-
152	Manholes	\$20,000.00	20,000.00		100%	-
153	Lighting Lot	\$39,160.00	32,831.69		84%	6,328.31
154	Gear Lot	\$73,570.00	-		0%	73,570.00
155	Site Material	\$155,725.00	82,618.25		53%	73,106.75
156	Site Labor	\$79,845.00	44,922.50		56%	34,922.50
157	Existing Plant Material	\$34,488.00	-		0%	34,488.00
158	Existing Plant Labor	\$44,883.00	-		0%	44,883.00
159	Well No. 3	\$4,933.00	-		0%	4,933.00
160	Well No. 5 Material	\$8,819.00	-		0%	8,819.00
161	RO Building Material	\$42,586.00	-	4,258.60	10%	38,327.40
162	RO Building Labor	\$77,390.00	-	7,739.00	10%	69,651.00
163	Clearwell Material	\$6,653.00	-		0%	6,653.00
164	Clearwell Labor	\$11,184.00	-		0%	11,184.00
165			-			-
166			-			-
167	Allowance - EP2 - Elec Equip & Controls		-			-
168	Elec Systems Analysis	\$75,000.00	37,500.00		50%	37,500.00
169	LV Transformers	\$125,000.00	-		0%	125,000.00
170	Control Panels	\$95,890.00	-		0%	95,890.00
171	Field Instrumentation	\$185,000.00	-	65,106.00	35%	119,894.00
172	MCCs	\$365,000.00	-		0%	365,000.00
173	Electrical Distribution Equipment	\$114,000.00	-		0%	114,000.00
174	SCADA Networking Integration	\$102,500.00	-		0%	102,500.00
175	HS Pump #3 Enclosure	\$85,273.00	-		0%	85,273.00
176			-			-
177	Earthwork		-			-
178	Site Preloading	\$194,820.00	194,820.00		100%	-
179	General Site Grading/Backfill	\$265,000.00	11,175.00		4%	253,825.00

Progress Estimate - Lump Sum Work

Contractor's Application for Payment

Owner: City of Tiffin	Owner's Project No.:
Engineer: MSA Professional Services	Engineer's Project No.: 13603016
Contractor: Tricon Construction Group	Contractor's Project No.:
Project: Water Treatment Plant Upgrades - City of Tiffin	
Contract:	

Application No.: 8	Application Period:	From 03/28/26	to 04/23/26	Application Date: 04/24/26
---------------------------	----------------------------	----------------------	--------------------	-----------------------------------

180	Bldg 10 - Foundations (Exc&BF)	\$25,630.00	-	-	0%	25,630.00
181	Bldg 20 - RO Foundations (Exc&BF)	\$45,250.00	30,616.00	30,616.00	68%	14,634.00
182	Bldg 20 - Aeration Tank Found (Ex&BF)	\$15,640.00	9,384.00	9,384.00	60%	6,256.00
183	Bldg 30 - Foundations (Exc&BF)	\$37,650.00	18,825.00	18,825.00	50%	18,825.00
184			-	-		-
185	Exterior Improvements		-	-		-
186	Asphalt Paving (Trail)	\$22,130.00	22,130.00	22,130.00	100%	-
187	Concrete Paving (Site)	\$130,288.00	-	-	0%	130,288.00
188	Chain Link Fencing	\$32,250.00	-	-	0%	32,250.00
189	Seeding	\$6,914.00	-	-	0%	6,914.00
190			-	-		-
191	Utilities		-	-		-
192	A - 12" W to Clearwell	\$32,544.00	29,289.60	29,289.60	90%	3,254.40
193	B - 8" W to Clearwell	\$25,663.00	20,530.40	20,530.40	80%	5,132.60
194	C - UG Storm Sewer North	\$48,686.00	38,948.80	38,948.80	80%	9,737.20
195	D - 12" W Aerator to Clearwell	\$18,549.00	16,694.10	16,694.10	90%	1,854.90
196	E - 12" W Bldg 10 to Bldg 20	\$8,554.00	7,698.60	7,698.60	90%	855.40
197	G - UG Storm Sewer East	\$67,822.00	67,822.00	67,822.00	100%	-
198	H & J - UG Storm Sewer West/South	\$87,552.00	83,174.40	83,174.40	95%	4,377.60
199	K - UG Storm Sewer Clearwell West	\$42,500.00	-	-	0%	42,500.00
200	F - UG Sanitary Manholes & Piping	\$165,835.00	149,251.50	149,251.50	90%	16,583.50
201	Roof Drains	\$2,500.00	-	-	0%	2,500.00
202	Bldg 20 - Process Drain Manhole	\$8,500.00	8,500.00	8,500.00	100%	-
203			-	-		-
204	Process Integration (Piping)		-	-		-
205	Structure 10 - Existing Bldg		-	-		-
206	Process Piping Materials	\$55,103.74	-	-	0%	55,103.74
207	Process Piping Labor	\$37,550.00	-	-	0%	37,550.00
208	Valves Materials	\$9,500.00	-	-	0%	9,500.00
209	Valves Labor	\$8,250.28	-	-	0%	8,250.28
210	Structure 20 - RO Building		-	-		-

Progress Estimate - Lump Sum Work

Contractor's Application for Payment

Owner: City of Tiffin
 Engineer: MSA Professional Services
 Contractor: Tricon Construction Group
 Project: Water Treatment Plant Upgrades - City of Tiffin
 Contract: _____

Owner's Project No.: _____
 Engineer's Project No.: 13603016
 Contractor's Project No.: _____

Application No.: 8 Application Period: From 03/28/26 to 04/23/26 Application Date: 04/24/26

211	Process Piping Materials	\$111,340.84	-			-	0%	111,340.84
212	Process Piping Labor	\$85,502.50	-			-	0%	85,502.50
213	Valves Materials	\$83,000.00	-		29,765.00	29,765.00	36%	53,235.00
214	Valves Labor	\$30,614.26	-			-	0%	30,614.26
215	Structure 30 - Clearwell		-			-		-
216	Process Piping Materials	\$62,822.42	-	7,658.00	2,820.00	10,478.00	17%	52,344.42
217	Process Piping Labor	\$69,588.64	-			-	0%	69,588.64
218	Valves Materials	\$42,830.00	-		10,554.50	10,554.50	25%	32,275.50
219	Valves Labor	\$26,450.68	-			-	0%	26,450.68
220	Insulation	\$6,825.00	-			-	0%	6,825.00
221			-			-		-
222	Pollution Control Equipment		-			-		-
223	Vertical Turbine Pumps Materials	\$115,300.00	-	2,700.00	112,600.00	115,300.00	100%	-
224	Vertical Turbine Pumps Labor	\$24,601.24	-			-	0%	24,601.24
225	Slide Gates Materials	\$24,155.00	-		24,155.00	24,155.00	100%	-
226	Slide Gates Labor	\$9,001.40	-			-	0%	9,001.40
227	Clearwell Leak Testing	\$18,144.00	-			-	0%	18,144.00
228	Lab Equipment	\$7,216.00	-		7,216.00	7,216.00	100%	-
229	Filter Media Replacement Materials	\$49,780.00	49,780.00			49,780.00	100%	-
230	Filter Media Replacement Labor	\$16,480.00	16,480.00			16,480.00	100%	-
231	Forced Draft Aerator Materials	\$125,890.00	-			-	0%	125,890.00
232	Forced Draft Aerator Labor	\$14,995.00	-			-	0%	14,995.00
233	RO System Materials	\$1,408,500.00	-			-	0%	1,408,500.00
234	RO System Labor	\$203,600.00	-			-	0%	203,600.00
235	Chem Sys Chlorine Fluoride Caustic	\$125,425.00	-			-	0%	125,425.00
236	Chem Systems Labor	\$41,582.00	-			-	0%	41,582.00
237			-			-		-
Original Contract Totals		\$ 12,182,553.00	\$ 2,577,764.99	\$1,235,139.18	\$ 293,126.08	\$ 4,106,030.25	34%	\$ 8,076,522.75

Stored Materials Summary

Contractor's Application for Payment

Owner:	City of Tiffin	Owner's Project No.:	
Engineer:	MSA	Engineer's Project No.:	
Contractor:	Tricon	Contractor's Project No.:	25-0125-1A
Project: Contract:			

Application No.: 8 Application Period: From 3/28/2026 to 4/30/2026 Application Date: 4/24/26

A Item No. (Lump Sum Tab) or Bid Item No. (Unit Price Tab)	B Supplier Invoice No.	C Submittal No. (with Specification Section No.)	D Description of Materials or Equipment Stored	E Storage Location	F Application No. When Materials Placed in Storage	G, H, I Materials Stored			J, K, L Incorporated in Work			M Materials Remaining in Storage (I-L) (\$)
						G Previous Amount Stored (\$)	H Amount Stored this Period (\$)	I Amount Stored to Date (G+H) (\$)	J Amount Previously Incorporated in the Work (\$)	K Amount Incorporated in the Work this Period (\$)	L Total Amount Incorporated in the Work (J+K) (\$)	
105		083459-001-1	Vault Doors	Onsite	4	\$ 21,050.00	\$ -	\$ 21,050.00	\$ -	\$ -	\$ -	\$ 21,050.00
213	039823, 039852	402323-001-1	12" PRV, 8" Gate Valve	Onsite	6	\$ 29,765.00	\$ -	\$ 29,765.00	\$ -	\$ -	\$ -	\$ 29,765.00
217	039852	402323-001-1	8" Gate Valves (3)	Onsite	6	\$ 9,034.50	\$ -	\$ 9,034.50	\$ -	\$ -	\$ -	\$ 9,034.50
223	0177001-IN	444256.10-001-1	LL & HS Pumps/ Motors	Offsite	6	\$ 112,600.00	\$ -	\$ 112,600.00	\$ -	\$ -	\$ -	\$ 112,600.00
225	040047	444276.30-001-0	Mechanical Slide Gates	Onsite	7	\$ 24,155.00	\$ -	\$ 24,155.00	\$ -	\$ -	\$ -	\$ 24,155.00
37	50035882168	03200-001-3	Clearwell Rebar	Onsite	7	\$ 25,283.00	\$ -	\$ 25,283.00	\$ -	\$ 25,283.00	\$ 25,283.00	\$ -
37	50035881578	03200-001-3	Clearwell Rebar	Onsite	7	\$ 24,024.00	\$ -	\$ 24,024.00	\$ -	\$ 24,024.00	\$ 24,024.00	\$ -
37	50035901450	03200-001-3	Clearwell Rebar	Onsite	7	\$ 22,318.00	\$ -	\$ 22,318.00	\$ -	\$ 22,318.00	\$ 22,318.00	\$ -
37	50035914613	03200-001-3	Clearwell Rebar	Onsite	7	\$ 15,090.70	\$ -	\$ 15,090.70	\$ -	\$ 15,090.70	\$ 15,090.70	\$ -
216	Y774097	402323-001-2	Clearwell Top Vent Pipes	Onsite	8	\$ -	\$ 2,820.00	\$ 2,820.00	\$ -	\$ -	\$ -	\$ 2,820.00
218	040370	402323-001-1	2" ARV Valve	Onsite	8	\$ -	\$ 1,520.00	\$ 1,520.00	\$ -	\$ -	\$ -	\$ 1,520.00
100	0177182-IN	077233-001-3	Clearwell Bilco Roof Hatches	Onsite	8	\$ -	\$ 5,193.00	\$ 5,193.00	\$ -	\$ -	\$ -	\$ 5,193.00
228	CC Receipt	444276.60-001-1	Lab Equipment - CL Mtr & Spectrophotometer	Onsite	8	\$ -	\$ 7,216.00	\$ 7,216.00	\$ -	\$ -	\$ -	\$ 7,216.00
129	Pay App #1	220000-001-3	AG Plumbing Fixtures	Offsite	8	\$ -	\$ 14,666.58	\$ 14,666.58	\$ -	\$ -	\$ -	\$ 14,666.58
171	044841	269000-001-3	Instrumentation	Onsite	8	\$ -	\$ 65,106.00	\$ 65,106.00	\$ -	\$ -	\$ -	\$ 65,106.00
								\$ -			\$ -	\$ -
								\$ -			\$ -	\$ -
								\$ -			\$ -	\$ -
								\$ -			\$ -	\$ -
								\$ -			\$ -	\$ -
								\$ -			\$ -	\$ -
Totals						\$ 283,320.20	\$ 96,521.58	\$ 379,841.78	\$ -	\$ 86,715.70	\$ 86,715.70	\$ 293,126.08



AGENDA INFORMATION
TIFFIN CITY COUNCIL COMMUNICATION

DATE:	May 1, 2026
AGENDA ITEM:	Discussion and Consideration of Approval of State Revolving Fund (SRF) Reimbursement Request #4 – Water Treatment Facility Upgrade Project
ACTION:	Motion

Background

The City of Tiffin is utilizing financing through the Iowa State Revolving Fund (SRF) to fund the Water Treatment Facility Upgrade project. Under SRF requirements, eligible project expenses must be paid by the City and then submitted to SRF for reimbursement.

Engineering and construction administration services are provided by MSA Professional Services under an approved professional services agreement for bidding support and construction-related services (CRS).

SRF Reimbursement Request #4 covers eligible engineering and construction administration costs associated with the Water Treatment Facility Upgrade project. These costs have been incurred, reviewed, and are eligible for reimbursement under the City’s SRF funding agreement.

SRF Reimbursement Request #4 includes costs billed by MSA Professional Services for work performed during the invoice period of March 8, 2026 through April 4, 2026, including:

- Construction administration activities
- Resident project representative (RPR) services
- Ongoing project oversight and coordination

All costs have been reviewed by staff and are consistent with the approved scope of services and SRF eligibility requirements.

Staff has reviewed the invoice and confirmed that the expenses are eligible for SRF reimbursement and align with the professional services agreement and project funding plan. Approval of this reimbursement request will allow the City to recover eligible project costs in a timely manner.

Staff Recommendation

Staff recommends approval of SRF Reimbursement Request #4 in the amount of \$1,210,696.33 and authorization for staff to submit the reimbursement request to the Iowa State Revolving Fund.

ATTACHMENTS: Reimbursement Request

CONSTRUCTION DISBURSEMENT REQUEST

Borrower:	City of Tiffin	Contact:	Doug Boldt, City Administrator
Street Address:	300 Railroad Street; PO Box 259	Email:	dboldt@tiffin-iowa.org
City, State, Zip	Tiffin, IA 52340	Phone:	319 545-2572
SRF Project #:	FS-52-25-DWSRF-001	Request Date:	5/5/2026
DNR Permit #(s):	2025-0171W	Request #:	4
		Final Request Yes or No:	NO



								Revenue Loan	Other Funding
								D0814R	
								Loan Amount	Amount
Expenses								\$ 14,384,000.00	
Legal and Municipal Advisor Expenses	Administrative Expenses	Engineering	Tricon Construction Contract (\$12,182,553.00)	Other Construction Contract if Applicable	Other Construction Contract if Applicable	Other Construction Contract if Applicable	Total Expenses	SRF Request Amount	Other Funding Request Amount
Initiation Fee							\$ 71,920.00	\$ 71,920.00	
Request #1		\$ 217,793.28	\$ 1,823,406.04				\$ 2,041,199.32	\$ 2,041,199.32	
Request #2		\$ 31,797.65	\$ 557,440.64				\$ 589,238.29	\$ 589,238.29	
Request #3		\$ 21,646.08	\$ 337,184.25				\$ 358,830.33	\$ 358,830.33	
Request #4		\$ 32,283.66	\$ 1,178,412.67				\$ 1,210,696.33	\$ 1,210,696.33	
Request #5							\$ -		
Request #6							\$ -		
Request #7							\$ -		
Request #8							\$ -		
Request #9							\$ -		
Request #10							\$ -		
Request #11							\$ -		
Request #12							\$ -		
Request #13							\$ -		
Request #14							\$ -		
Request #15							\$ -		
Request #16							\$ -		
Request #17							\$ -		
Request #18							\$ -		
Request #19							\$ -		
Request #20							\$ -		
Request #21							\$ -		
Request #22							\$ -		
Total	\$ -	\$ -	\$ 303,520.67	\$ 3,896,443.60	\$ -	\$ -	\$ 4,271,884.27	\$ 4,271,884.27	\$ -

I hereby certify that this request for disbursement of is a true and accurate request for disbursement; that it is made in accordance with the terms and conditions of the above referenced Agreements; and that the corresponding invoices attached to the request and this request represents eligible project costs not previously requested or to be requested from other sources.

Available to Draw
\$ 10,112,115.73

Typed or Printed Name and Title

Signature of Authorized Representative

Contractor's Application for Payment

Owner: <u>City of Tiffin</u>	Owner's Project No.: _____
Engineer: <u>MSA Professional Services</u>	Engineer's Project No.: <u>13603016</u>
Contractor: <u>Tricon Construction Group</u>	Contractor's Project No.: _____
Project: <u>Water Treatment Plant Upgrades - City of Tiffin</u>	
Contract: <u>Water Treatment Plant Upgrades</u>	
Application No.: <u>8</u>	Application Date: <u>4/24/2026</u>
Application Period: From <u>3/28/2026</u> to <u>4/23/2026</u>	

1. Original Contract Price	\$	12,182,553.00
2. Net change by Change Orders	\$	12,420.34
3. Current Contract Price (Line 1 + Line 2)	\$	12,194,973.34
4. Total Work completed and materials stored to date	\$	4,101,519.57
(Sum of Column G Lump Sum Total and Column G Unit Price Total)	\$	4,101,519.57
5. Retainage		
a. <u>5%</u> X \$ <u>3,808,393.49</u> Work Completed	\$	190,419.67
b. <u>5%</u> X \$ <u>293,126.08</u> Stored Materials	\$	14,656.30
c. Total Retainage (Line 5.a + Line 5.b)	\$	205,075.97
6. Amount eligible to date (Line 4 - Line 5.c)	\$	3,896,443.60
7. Less previous payments (Line 6 from prior application)	\$	2,718,030.93
8. Amount due this application	\$	1,178,412.67
9. Balance to finish, including retainage (Line 3 - Line 4, plus 5c)	\$	8,298,529.74

Contractor's Certification
 The undersigned Contractor certifies, to the best of its knowledge, the following:

Contractor: Tricon Construction Group
Signature: Mary K. Stone **Date:** 4/29/2026

PAYMENT OF: \$ _____ **1,178,412.67**
 (line 8 or other - attach explanation of the other amount)

<p>Recommended by Engineer</p> <p>By: <u>Clint Wiener</u></p> <p>Title: <u>Senior Project Engineer</u></p> <p>Date: <u>April 29, 2026</u></p>	<p>Approved by Owner</p> <p>By: _____</p> <p>Title: _____</p> <p>Date: _____</p>
<p>Approved by Funding Agency</p> <p>By: _____</p> <p>Title: _____</p>	<p>By: _____</p> <p>Title: _____</p>
<p>Date: _____</p>	<p>Date: _____</p>

Progress Estimate - Lump Sum Work

Contractor's Application for Payment

Owner: <u>City of Tiffin</u>	Owner's Project No.: _____
Engineer: <u>MSA Professional Services</u>	Engineer's Project No.: <u>13603016</u>
Contractor: <u>Tricon Construction Group</u>	Contractor's Project No.: _____
Project: <u>Water Treatment Plant Upgrades - City of Tiffin</u>	
Contract: _____	

Application No.: 8 **Application Period:** **From** 03/28/26 **to** 04/23/26 **Application Date:** 04/24/26

A	B	C	D		F	G	H	I
			(D + E) From Previous Application (\$)	This Period (\$)				
Item No.	Description	Scheduled Value (\$)			Materials Currently Stored (not in D or E) (\$)	Work Completed and Materials Stored to Date (D + E + F) (\$)	% of Scheduled Value (G / C) (%)	Balance to Finish (C - G) (\$)
Original Contract								
00	General Requirements					-		-
01	General Conditions	\$588,953.00	234,461.22	39,076.87		273,538.09	46%	315,414.91
02	Bond/Buider's Risk Insurance	\$199,542.00	199,542.00			199,542.00	100%	-
03	Allowance EP1 - Generator & ATS	\$329,890.00	329,890.00			329,890.00	100%	-
04	Allowance EP2 Electrical Equipment	Line item 167	-			-		-
05	Allowance - Electrical Service	\$5,000.00	-			-	0%	5,000.00
06	Mobilization	\$350,000.00	240,000.00			240,000.00	69%	110,000.00
07	Site Testing	\$53,736.00	13,383.19	1,354.59		14,737.78	27%	38,998.22
08	Traffic Control	\$10,000.00	1,000.00	1,000.00		2,000.00	20%	8,000.00
09	Portable Toilets	\$5,400.00	1,187.20	148.40		1,335.60	25%	4,064.40
10	Dumpster	\$14,600.00	3,000.00	500.00		3,500.00	24%	11,100.00
11	Concrete Washout Pit	\$2,400.00	240.00	240.00		480.00	20%	1,920.00
12	Erosion Control	\$8,250.00	3,500.00			3,500.00	42%	4,750.00
13			-			-		-
14	Existing Conditions		-			-		-
15	Structure Demolition	\$33,445.00	-			-	0%	33,445.00
16			-			-		-
17	Concrete		-			-		-
18	Structure 10 - Existing Building		-			-		-
19	Rebar - Materials	\$54,588.00	-			-	0%	54,588.00
20	Rebar - Labor	\$46,399.80	-			-	0%	46,399.80
21	Concrete - Materials	\$165,884.00	-			-	0%	165,884.00
22	Concrete - Labor	\$91,308.20	-			-	0%	91,308.20
23	Structure 20 - RO Building		-			-		-
24	Rebar - Materials	\$84,556.00	76,100.40			76,100.40	90%	8,455.60

Progress Estimate - Lump Sum Work

Contractor's Application for Payment

Owner: City of Tiffin
 Engineer: MSA Professional Services
 Contractor: Tricon Construction Group
 Project: Water Treatment Plant Upgrades - City of Tiffin
 Contract: _____

Owner's Project No.: _____
 Engineer's Project No.: 13603016
 Contractor's Project No.: _____

Application No.: 8 Application Period: From 03/28/26 to 04/23/26 Application Date: 04/24/26

25	Rebar - Labor	\$71,872.60	64,685.34		64,685.34	90%	7,187.26
26	Base Footings Materials	\$89,665.00	89,665.00		89,665.00	100%	-
27	Base Footings Labor	\$49,315.75	49,315.75		49,315.75	100%	-
28	Wall Footings Materials	\$98,663.00	98,663.00		98,663.00	100%	-
29	Wall Footings Labor	\$54,264.65	54,264.65		54,264.65	100%	-
30	Floor Slab Materials	\$156,442.00	-		-	0%	156,442.00
31	Floor Slab Labor	\$88,874.50	-		-	0%	88,874.50
32	Equipment Pads Materials	\$1,515.00	151.50		151.50	10%	1,363.50
33	Equipment Pads Labor	\$3,451.50	345.15		345.15	10%	3,106.35
34	Precast Concrete Materials	\$575,000.00	12,125.00	505,375.00	517,500.00	90%	57,500.00
35	Precast Concrete Labor	\$204,412.67	-	132,868.24	132,868.24	65%	71,544.43
36	Structure 30- Clearwell		-		-		-
37	Rebar Materials	\$204,551.00	-	132,958.15	132,958.15	65%	71,592.85
38	Rebar labor	\$112,503.05	-	73,126.98	73,126.98	65%	39,376.07
39	Mat Foundation - Materials	\$123,255.00	-	123,255.00	123,255.00	100%	-
40	Mat Foundation - Labor	\$68,450.80	-	68,450.80	68,450.80	100%	-
41	Walls - Materials	\$78,452.00	-	50,993.80	50,993.80	65%	27,458.20
42	Walls - Labor	\$98,065.00	-	53,935.75	53,935.75	55%	44,129.25
43	Elevated Slab - Materials	\$198,553.00	-		-	0%	198,553.00
44	Elevated Slab - Labor	\$109,204.15	-		-	0%	109,204.15
45	Precast Concrete - Materials	\$210,000.00	-		-	0%	210,000.00
46	Precast Concrete - Labor	\$61,058.33	-		-	0%	61,058.33
47			-		-		-
48	Masonry		-		-		-
49	Masonry - Materials	\$15,116.00	-		-	0%	15,116.00
50	Masonry - Labor	\$50,603.00	-		-	0%	50,603.00
51			-		-		-
52	Metals		-		-		-
53	Metal Fabrications - Materials	\$57,200.00	-		-	0%	57,200.00
54	Metal Fabrications - Labor	\$13,556.25	-		-	0%	13,556.25
55	Handrails & Railings Labor	\$5,966.50	-		-	0%	5,966.50

Progress Estimate - Lump Sum Work

Contractor's Application for Payment

Owner: City of Tiffin	Owner's Project No.:
Engineer: MSA Professional Services	Engineer's Project No.: 13603016
Contractor: Tricon Construction Group	Contractor's Project No.:
Project: Water Treatment Plant Upgrades - City of Tiffin	
Contract:	

Application No.: 8 **Application Period:** **From** 03/28/26 **to** 04/23/26 **Application Date:** 04/24/26

56	Grating - Labor	\$2,777.25	-		-	0%	2,777.25
57			-		-		-
58	Wood, Plastics and Composites		-		-		-
59	Structure 10 - Existing Building		-		-		-
60	Walls, Headers, Mezz Hardware - M	\$15,568.75	-		-	0%	15,568.75
61	Walls, Headers, Mezz Hardware - L	\$45,669.32	-		-	0%	45,669.32
62	Trusses - Materials	\$15,887.00	-		-	0%	15,887.00
63	Trusses - Labor	\$55,229.36	-		-	0%	55,229.36
64	Structure 20 - RO Building		-		-		-
65	Walls, Headers, Mezz Hardware - M	\$25,568.65	-		-	0%	25,568.65
66	Walls, Headers, Mezz Hardware - L	\$55,565.78	-		-	0%	55,565.78
67	Trusses - Materials	\$33,966.50	-		-	0%	33,966.50
68	Trusses - Labor	\$79,156.72	-		-	0%	79,156.72
69	FRP Grating - Materials	\$32,000.00	-	500.00	500.00	2%	31,500.00
70	FRP Grating - Labor	\$17,836.00	-		-	0%	17,836.00
71	Structural 30 - Clearwell		-		-		-
72	Walls, Headers, Hardware - Materials	\$3,692.40	-		-	0%	3,692.40
73	Walls, Headers, Hardware - Labor	\$18,569.52	-		-	0%	18,569.52
74	Trusses - Materials	\$5,858.50	-		-	0%	5,858.50
75	Trusses - Labor	\$16,979.50	-		-	0%	16,979.50
76			-		-		-
77	Thermal & Moisture Protection		-		-		-
78	Blown Insulation	\$20,001.00	-		-	0%	20,001.00
79	Structure 10 - Existing Building		-		-		-
80	Metal Roofing - Materials	\$11,566.00	-		-	0%	11,566.00
81	Metal Roofing - Labor	\$6,541.50	-		-	0%	6,541.50
82	Preformed Metal Soffit - Materials	\$1,586.00	-		-	0%	1,586.00
83	Preformed Metal Soffit - Labor	\$1,852.50	-		-	0%	1,852.50
84	Gutters & Downspouts - Materials	\$2,500.00	-		-	0%	2,500.00
85	Gutters & Downspouts - Labor	\$3,215.00	-		-	0%	3,215.00
86	Structure 20 - RO Building		-		-		-

Progress Estimate - Lump Sum Work

Contractor's Application for Payment

Owner: <u>City of Tiffin</u>	Owner's Project No.: _____
Engineer: <u>MSA Professional Services</u>	Engineer's Project No.: <u>13603016</u>
Contractor: <u>Tricon Construction Group</u>	Contractor's Project No.: _____
Project: <u>Water Treatment Plant Upgrades - City of Tiffin</u>	
Contract: _____	

Application No.: 8 **Application Period:** **From** 03/28/26 **to** 04/23/26 **Application Date:** 04/24/26

87	Metal Roofing - Materials	\$35,256.00	-			-	0%	35,256.00
88	Metal Roofing - Labor	\$40,587.00	-			-	0%	40,587.00
89	Preformed Metal Soffit - Materials	\$5,877.00	-			-	0%	5,877.00
90	Preformed Metal Soffit - Labor	\$9,992.12	-			-	0%	9,992.12
91	Gutters & Downspouts - Materials	\$5,600.00	-			-	0%	5,600.00
92	Gutters & Downspouts - Labor	\$8,544.32	-			-	0%	8,544.32
93	Structure 30 - Clearwell		-			-		-
94	Metal Roofing - Materials	\$9,442.00	-			-	0%	9,442.00
95	Metal Roofing - Labor	\$11,566.68	-			-	0%	11,566.68
96	Preformed Metal Soffit - Materials	\$3,655.00	-			-	0%	3,655.00
97	Preformed Metal Soffit - Labor	\$6,552.46	-			-	0%	6,552.46
98	Gutters & Downspouts - Materials	\$2,651.00	-			-	0%	2,651.00
99	Gutters & Downspouts - Labor	\$3,215.42	-			-	0%	3,215.42
100	Roof Hatches - Materials	\$6,200.00	-		5,193.00	5,193.00	84%	1,007.00
101			-			-		-
102	Openings		-			-		-
103	HM Frames, Doors & Hardware-Materials	\$53,528.00	-			-	0%	53,528.00
104	HM Frames, Doors & Hardware-Labor	\$6,890.00	-			-	0%	6,890.00
105	Vault Doors - Materials	\$49,611.00	-		21,050.00	21,050.00	42%	28,561.00
106	Vault Doors - Labor	\$3,110.00	-			-	0%	3,110.00
107	Overhead Door	\$43,790.00	-			-	0%	43,790.00
108	Aluminum Windows	\$8,996.00	-			-	0%	8,996.00
109			-			-		-
110	Finishes		-			-		-
111	Resilient Base	\$2,500.00	-			-	0%	2,500.00
112	Epoxy Flooring	\$67,408.00	-			-	0%	67,408.00
113	High Performance Coatings	\$68,724.00	13,314.75			13,314.75	19%	55,409.25
114			-			-		-
115	Specialties		-			-		-
116	Signage	\$450.00	-			-	0%	450.00
117	Metal Lockers	\$7,100.00	-			-	0%	7,100.00

Progress Estimate - Lump Sum Work

Contractor's Application for Payment

Owner: City of Tiffin
 Engineer: MSA Professional Services
 Contractor: Tricon Construction Group
 Project: Water Treatment Plant Upgrades - City of Tiffin
 Contract: _____

Owner's Project No.: _____
 Engineer's Project No.: 13603016
 Contractor's Project No.: _____

Application No.: 8 Application Period: From 03/28/26 to 04/23/26 Application Date: 04/24/26

Item No.	Description	Contract Value	Applied Value	Remaining Value	Applied %	Contract Value
118	Metal Storage Systems	\$6,947.00	-	-	0%	6,947.00
119	Fire Extinguishers	\$854.00	-	-	0%	854.00
120			-	-		-
121	Furnishings		-	-		-
122	Lab Casework	\$18,810.00	-	-	0%	18,810.00
123			-	-		-
124	Plumbing		-	-		-
125	Bldg 20 Trench Drains/UG Plumbing Mat	\$26,000.00	-	21,000.00	81%	5,000.00
126	Bldg 20 Trench Drains/UG Plumbing Labor	\$25,000.00	-	8,000.00	32%	17,000.00
127	Bldg 20 AG Plumbing Materials	\$5,000.00	-	-	0%	5,000.00
128	Bldg 20 AG Plumbing Materials Labor	\$20,000.00	-	-	0%	20,000.00
129	Bldg 20 Plumbing Fixtures	\$15,500.00	-	14,666.58	95%	833.42
130	Bldg 20 AG Plumbing Labor	\$28,000.00	-	-	0%	28,000.00
131	Bldg 10 AG Plumbing Materials	\$5,000.00	-	-	0%	5,000.00
132	Bldg 10 AG Plumbing Labor	\$20,000.00	-	-	0%	20,000.00
133	Insulation	\$5,000.00	-	-	0%	5,000.00
134			-	-		-
135	HVAC/Dehumidifier		-	-		-
136	EF & Destrat	\$37,066.00	-	-	0%	37,066.00
137	EUH	\$9,492.00	-	-	0%	9,492.00
138	GUH	\$3,660.00	-	-	0%	3,660.00
139	LV & Dampers	\$15,828.00	-	-	0%	15,828.00
140	Split & F/CU	\$20,788.00	-	-	0%	20,788.00
141	Dehumidifiers	\$18,166.00	-	-	0%	18,166.00
142	Duct Material	\$4,003.00	-	-	0%	4,003.00
143	HVAC Materials	\$4,497.00	-	-	0%	4,497.00
144	HVAC Labor	\$117,908.00	-	-	0%	117,908.00
145	Insulation	\$10,000.00	-	-	0%	10,000.00
146	Test & Balance	\$5,750.00	-	-	0%	5,750.00
147			-	-		-
148	Electrical & Controls		-	-		-

Progress Estimate - Lump Sum Work

Contractor's Application for Payment

Owner:	City of Tiffin	Owner's Project No.:	
Engineer:	MSA Professional Services	Engineer's Project No.:	13603016
Contractor:	Tricon Construction Group	Contractor's Project No.:	
Project:	Water Treatment Plant Upgrades - City of Tiffin		
Contract:			

Application No.: 8 **Application Period:** **From** 03/28/26 **to** 04/23/26 **Application Date:** 04/24/26

149	Electrical		-			-		-
150	Mobilization - Neumiller	\$122,150.00	84,825.00			84,825.00	69%	37,325.00
151	Submittals	\$15,114.00	15,114.00			15,114.00	100%	-
152	Manholes	\$20,000.00	20,000.00			20,000.00	100%	-
153	Lighting Lot	\$39,160.00	32,831.69			32,831.69	84%	6,328.31
154	Gear Lot	\$73,570.00	-			-	0%	73,570.00
155	Site Material	\$155,725.00	82,618.25			82,618.25	53%	73,106.75
156	Site Labor	\$79,845.00	44,922.50			44,922.50	56%	34,922.50
157	Existing Plant Material	\$34,488.00	-			-	0%	34,488.00
158	Existing Plant Labor	\$44,883.00	-			-	0%	44,883.00
159	Well No. 3	\$4,933.00	-			-	0%	4,933.00
160	Well No. 5 Material	\$8,819.00	-			-	0%	8,819.00
161	RO Building Material	\$42,586.00	-	4,258.60		4,258.60	10%	38,327.40
162	RO Building Labor	\$77,390.00	-	7,739.00		7,739.00	10%	69,651.00
163	Clearwell Material	\$6,653.00	-			-	0%	6,653.00
164	Clearwell Labor	\$11,184.00	-			-	0%	11,184.00
165			-			-		-
166			-			-		-
167	Allowance - EP2 - Elec Equip & Controls		-			-		-
168	Elec Systems Analysis	\$75,000.00	37,500.00			37,500.00	50%	37,500.00
169	LV Transformers	\$125,000.00	-			-	0%	125,000.00
170	Control Panels	\$95,890.00	-			-	0%	95,890.00
171	Field Instrumentation	\$185,000.00	-		65,106.00	65,106.00	35%	119,894.00
172	MCCs	\$365,000.00	-			-	0%	365,000.00
173	Electrical Distribution Equipment	\$114,000.00	-			-	0%	114,000.00
174	SCADA Networking Integration	\$102,500.00	-			-	0%	102,500.00
175	HS Pump #3 Enclosure	\$85,273.00	-			-	0%	85,273.00
176			-			-		-
177	Earthwork		-			-		-
178	Site Preloading	\$194,820.00	194,820.00			194,820.00	100%	-
179	General Site Grading/Backfill	\$265,000.00	11,175.00			11,175.00	4%	253,825.00

Progress Estimate - Lump Sum Work

Contractor's Application for Payment

Owner: City of Tiffin	Owner's Project No.:
Engineer: MSA Professional Services	Engineer's Project No.: 13603016
Contractor: Tricon Construction Group	Contractor's Project No.:
Project: Water Treatment Plant Upgrades - City of Tiffin	
Contract:	

Application No.: 8	Application Period:	From 03/28/26	to 04/23/26	Application Date: 04/24/26
---------------------------	----------------------------	----------------------	--------------------	-----------------------------------

180	Bldg 10 - Foundations (Exc&BF)	\$25,630.00	-	-	-	0%	25,630.00
181	Bldg 20 - RO Foundations (Exc&BF)	\$45,250.00	30,616.00	30,616.00	30,616.00	68%	14,634.00
182	Bldg 20 - Aeration Tank Found (Ex&BF)	\$15,640.00	9,384.00	9,384.00	9,384.00	60%	6,256.00
183	Bldg 30 - Foundations (Exc&BF)	\$37,650.00	18,825.00	18,825.00	18,825.00	50%	18,825.00
184			-	-	-		-
185	Exterior Improvements		-	-	-		-
186	Asphalt Paving (Trail)	\$22,130.00	22,130.00	22,130.00	22,130.00	100%	-
187	Concrete Paving (Site)	\$130,288.00	-	-	-	0%	130,288.00
188	Chain Link Fencing	\$32,250.00	-	-	-	0%	32,250.00
189	Seeding	\$6,914.00	-	-	-	0%	6,914.00
190			-	-	-		-
191	Utilities		-	-	-		-
192	A - 12" W to Clearwell	\$32,544.00	29,289.60	29,289.60	29,289.60	90%	3,254.40
193	B - 8" W to Clearwell	\$25,663.00	20,530.40	20,530.40	20,530.40	80%	5,132.60
194	C - UG Storm Sewer North	\$48,686.00	38,948.80	38,948.80	38,948.80	80%	9,737.20
195	D - 12" W Aerator to Clearwell	\$18,549.00	16,694.10	16,694.10	16,694.10	90%	1,854.90
196	E - 12" W Bldg 10 to Bldg 20	\$8,554.00	7,698.60	7,698.60	7,698.60	90%	855.40
197	G - UG Storm Sewer East	\$67,822.00	67,822.00	67,822.00	67,822.00	100%	-
198	H & J - UG Storm Sewer West/South	\$87,552.00	83,174.40	83,174.40	83,174.40	95%	4,377.60
199	K - UG Storm Sewer Clearwell West	\$42,500.00	-	-	-	0%	42,500.00
200	F - UG Sanitary Manholes & Piping	\$165,835.00	149,251.50	149,251.50	149,251.50	90%	16,583.50
201	Roof Drains	\$2,500.00	-	-	-	0%	2,500.00
202	Bldg 20 - Process Drain Manhole	\$8,500.00	8,500.00	8,500.00	8,500.00	100%	-
203			-	-	-		-
204	Process Integration (Piping)		-	-	-		-
205	Structure 10 - Existing Bldg		-	-	-		-
206	Process Piping Materials	\$55,103.74	-	-	-	0%	55,103.74
207	Process Piping Labor	\$37,550.00	-	-	-	0%	37,550.00
208	Valves Materials	\$9,500.00	-	-	-	0%	9,500.00
209	Valves Labor	\$8,250.28	-	-	-	0%	8,250.28
210	Structure 20 - RO Building		-	-	-		-

Progress Estimate - Lump Sum Work

Contractor's Application for Payment

Owner: City of Tiffin
 Engineer: MSA Professional Services
 Contractor: Tricon Construction Group
 Project: Water Treatment Plant Upgrades - City of Tiffin
 Contract: _____

Owner's Project No.: _____
 Engineer's Project No.: 13603016
 Contractor's Project No.: _____

Application No.: 8 Application Period: From 03/28/26 to 04/23/26 Application Date: 04/24/26

211	Process Piping Materials	\$111,340.84	-			-	0%	111,340.84
212	Process Piping Labor	\$85,502.50	-			-	0%	85,502.50
213	Valves Materials	\$83,000.00	-		29,765.00	29,765.00	36%	53,235.00
214	Valves Labor	\$30,614.26	-			-	0%	30,614.26
215	Structure 30 - Clearwell		-			-		-
216	Process Piping Materials	\$62,822.42	-	7,658.00	2,820.00	10,478.00	17%	52,344.42
217	Process Piping Labor	\$69,588.64	-			-	0%	69,588.64
218	Valves Materials	\$42,830.00	-		10,554.50	10,554.50	25%	32,275.50
219	Valves Labor	\$26,450.68	-			-	0%	26,450.68
220	Insulation	\$6,825.00	-			-	0%	6,825.00
221			-			-		-
222	Pollution Control Equipment		-			-		-
223	Vertical Turbine Pumps Materials	\$115,300.00	-	2,700.00	112,600.00	115,300.00	100%	-
224	Vertical Turbine Pumps Labor	\$24,601.24	-			-	0%	24,601.24
225	Slide Gates Materials	\$24,155.00	-		24,155.00	24,155.00	100%	-
226	Slide Gates Labor	\$9,001.40	-			-	0%	9,001.40
227	Clearwell Leak Testing	\$18,144.00	-			-	0%	18,144.00
228	Lab Equipment	\$7,216.00	-		7,216.00	7,216.00	100%	-
229	Filter Media Replacement Materials	\$49,780.00	49,780.00			49,780.00	100%	-
230	Filter Media Replacement Labor	\$16,480.00	16,480.00			16,480.00	100%	-
231	Forced Draft Aerator Materials	\$125,890.00	-			-	0%	125,890.00
232	Forced Draft Aerator Labor	\$14,995.00	-			-	0%	14,995.00
233	RO System Materials	\$1,408,500.00	-			-	0%	1,408,500.00
234	RO System Labor	\$203,600.00	-			-	0%	203,600.00
235	Chem Sys Chlorine Fluoride Caustic	\$125,425.00	-			-	0%	125,425.00
236	Chem Systems Labor	\$41,582.00	-			-	0%	41,582.00
237			-			-		-
Original Contract Totals		\$ 12,182,553.00	\$ 2,577,764.99	\$1,235,139.18	\$ 293,126.08	\$ 4,106,030.25	34%	\$ 8,076,522.75

Stored Materials Summary

Contractor's Application for Payment

Owner:	City of Tiffin	Owner's Project No.:	
Engineer:	MSA	Engineer's Project No.:	
Contractor:	Tricon	Contractor's Project No.:	25-0125-1A
Project Contract:			

Application No.:	8	Application Period:	From 3/28/2026 to 4/30/2026	Application Date:	4/24/26
------------------	---	---------------------	-----------------------------	-------------------	---------

A Item No. (Lump Sum Tab) or Bid Item No. (Unit Price Tab)	B Supplier Invoice No.	C Submittal No. (with Specification Section No.)	D Description of Materials or Equipment Stored	E Storage Location	F Application No. When Materials Placed in Storage	G, H, I Materials Stored			J, K, L Incorporated in Work			M Materials Remaining in Storage (I-L) (\$)
						G Previous Amount Stored (\$)	H Amount Stored this Period (\$)	I Amount Stored to Date (G+H) (\$)	J Amount Previously Incorporated in the Work (\$)	K Amount Incorporated in the Work this Period (\$)	L Total Amount Incorporated in the Work (J+K) (\$)	
105		083459-001-1	Vault Doors	Onsite	4	\$ 21,050.00	\$ -	\$ 21,050.00	\$ -	\$ -	\$ -	\$ 21,050.00
213	039823, 039852	402323-001-1	12" PRV, 8" Gate Valve	Onsite	6	\$ 29,765.00	\$ -	\$ 29,765.00	\$ -	\$ -	\$ -	\$ 29,765.00
217	039852	402323-001-1	8" Gate Valves (3)	Onsite	6	\$ 9,034.50	\$ -	\$ 9,034.50	\$ -	\$ -	\$ -	\$ 9,034.50
223	0177001-IN	444256.10-001-1	LL & HS Pumps/ Motors	Offsite	6	\$ 112,600.00	\$ -	\$ 112,600.00	\$ -	\$ -	\$ -	\$ 112,600.00
225	040047	444276.30-001-0	Mechanical Slide Gates	Onsite	7	\$ 24,155.00	\$ -	\$ 24,155.00	\$ -	\$ -	\$ -	\$ 24,155.00
37	50035882168	03200-001-3	Clearwell Rebar	Onsite	7	\$ 25,283.00	\$ -	\$ 25,283.00	\$ -	\$ 25,283.00	\$ 25,283.00	\$ -
37	50035881578	03200-001-3	Clearwell Rebar	Onsite	7	\$ 24,024.00	\$ -	\$ 24,024.00	\$ -	\$ 24,024.00	\$ 24,024.00	\$ -
37	50035901450	03200-001-3	Clearwell Rebar	Onsite	7	\$ 22,318.00	\$ -	\$ 22,318.00	\$ -	\$ 22,318.00	\$ 22,318.00	\$ -
37	50035914613	03200-001-3	Clearwell Rebar	Onsite	7	\$ 15,090.70	\$ -	\$ 15,090.70	\$ -	\$ 15,090.70	\$ 15,090.70	\$ -
216	Y774097	402323-001-2	Clearwell Top Vent Pipes	Onsite	8	\$ -	\$ 2,820.00	\$ 2,820.00	\$ -	\$ -	\$ -	\$ 2,820.00
218	040370	402323-001-1	2" ARV Valve	Onsite	8	\$ -	\$ 1,520.00	\$ 1,520.00	\$ -	\$ -	\$ -	\$ 1,520.00
100	0177182-IN	077233-001-3	Clearwell Bilco Roof Hatches	Onsite	8	\$ -	\$ 5,193.00	\$ 5,193.00	\$ -	\$ -	\$ -	\$ 5,193.00
228	CC Receipt	444276.60-001-1	Lab Equipment - CL Mtr & Spectrophotometer	Onsite	8	\$ -	\$ 7,216.00	\$ 7,216.00	\$ -	\$ -	\$ -	\$ 7,216.00
129	Pay App #1	220000-001-3	AG Plumbing Fixtures	Offsite	8	\$ -	\$ 14,666.58	\$ 14,666.58	\$ -	\$ -	\$ -	\$ 14,666.58
171	044841	269000-001-3	Instrumentation	Onsite	8	\$ -	\$ 65,106.00	\$ 65,106.00	\$ -	\$ -	\$ -	\$ 65,106.00
								\$ -			\$ -	\$ -
								\$ -			\$ -	\$ -
								\$ -			\$ -	\$ -
								\$ -			\$ -	\$ -
								\$ -			\$ -	\$ -
								\$ -			\$ -	\$ -
Totals						\$ 283,320.20	\$ 96,521.58	\$ 379,841.78	\$ -	\$ 86,715.70	\$ 86,715.70	\$ 293,126.08



INVOICE

TO MAKE A PAYMENT BY CREDIT CARD, PLEASE REQUEST A SECURE LINK VIA COLLECTIONS@MSA-PS.COM. A 3% SERVICE FEE WILL BE ADDED TO INVOICES PAID BY CREDIT CARD. PAST DUE BALANCES ARE SUBJECT TO AN INTEREST RATE OF 1.5% PER MONTH.

City of Tiffin
PO Box 259
300 Railroad Street
Tiffin, IA 52340

Invoice No: 028435
Invoice Date: 4/28/2026
Invoice Terms: Due upon receipt
Project No: R13603021.00
Project Manager: Clint Wiene
Client Liaison: Andrew Inhelder
Customer Ref:

From 03/08/2026 To 04/04/2026

R13603021.00 Tiffin Water Treatment Facility Upgrade Bidding & CRS

Progress detail

Phase	Fee	Percent complete	Previous billing	Current billing	Remaining contract
Bidding	32,000.00	100.00%	32,000.00	0.00	0.00
Construction Administration	374,000.00	44.65%	146,994.52	19,982.40	207,023.08
Post Construction	44,000.00	0.00%	0.00	0.00	44,000.00
Subtotal	450,000.00	44.22%	178,994.52	19,982.40	251,023.08

R13603021.00.300 - RPR

Subtotal RPR **12,301.26**

Total **32,283.66**

Please include the MSA Invoice Number and Project Number with your payment.

ACH Payments:

ach@msa-ps.com
Account Number: 101065930
Routing Number: 075901590
Bank Information: ACH/Wire, Baraboo State Bank, 101 3rd Avenue
Baraboo, WI 53913

Check Payments:

MSA
1230 South Boulevard
Baraboo, WI 53913



**AGENDA INFORMATION
TIFFIN CITY COUNCIL COMMUNICATION**

DATE:	May 1, 2026
AGENDA ITEM:	Discussion and Consideration of Change Order #15 – Boomerang Corporation – North Park Road Improvements Project
ACTION:	Motion

Background

The City entered into a construction contract with Boomerang Corporation for the North Park Road Improvements project following the December 17, 2024, letting. The project includes roadway, storm sewer, and associated infrastructure improvements.

During construction sequencing for Structure S-06 (cast-in-place), a need was identified to temporarily convey stormwater flows from an upstream detention basin into the newly installed 72-inch culvert to maintain system functionality and prevent backup during construction activities.

Change Order No. 15 is a non-substantial change order that adds a temporary storm sewer pipe to maintain flow conveyance during construction of Structure S-06. The change is necessary to safely manage stormwater flows while work continues and does not impact the project schedule.

Change Order No. 15 adds the following new item of work 20 linear feet of 18-inch HDPE storm sewer pipe to provide temporary flow conveyance from approximately Station 222+67 to Station 222+47.

This temporary pipe ties the detention basin outlet located outside of the right-of-way into the new 72-inch culvert, allowing stormwater to bypass the S-06 construction area until permanent work is completed.

Change Order Details:

- Change Order Number: 15
- Type: Non-Substantial
- Change Order Amount: \$1,250.00
- Unit Price: \$62.50 per linear foot
- Contract Time Impact: None

The unit price is below the average bid price (\$69.00/LF) and well below the maximum bid price identified in the bid analysis. No contractor markup is included.

Staff Recommendation

Staff recommends approval of Change Order No. 15 to the North Park Road Improvements project contract with Boomerang Corporation in the amount of \$1,250.00, increasing the total contract amount to \$5,555,699.41.

ATTACHMENTS: Change Order



City of Tiffin - Iowa

Change Order Details

52-7662-615

Description	STP-U-7662(615)--70-52, Letting Date- December 17, 2024
Prime Contractor	Boomerang Corp. 13225 Circle Dr Suite A, Anamosa, IA 52205 Anamosa, IA, IA 52205
Change Order	15
Status	Pending
Date Created	04/23/2026
Type	Non-Substantial
Summary	Add item for temporary pipe for flow conveyance into 72in culvert for temporary flow conveyance during S-06 installation.
Change Order Description	8220: Add item for 2503-0111018 STORM SEWER GRAVITY MAIN, TRENCHED, HIGH DENSITY POLYETHYLENE PIPE (HDPE), 18 IN.
Awarded Project Amount	\$5,458,891.91
Authorized Project Amount	\$5,554,449.41
Change Order Amount	\$1,250.00
Revised Project Amount	\$5,555,699.41

B-Reason for Change

8220: Add 20 LF of 18IN HDPE temporary pipe from approx. STA 222+67 to STA 222+47. This temporary pipe is intended to tie into the detention basin outlet outside of the ROW which is the primary flow inlet into the North Park Road storm system, the temporary 18in pipe will be outlet into the new 72in culvert which is already installed to send flows into the new system while construction of the structure S-06 (cast-in-place) takes place (the 72in culvert outlets from S-06).

C-Settlement for cost(s) of change

8220: Agreed unit price.

D-Justification for cost(s)

8220: Unit price (\$62.50/LF) is below the average unit bid price of the same item (\$69.00/LF) and also below the maximum unit bid price (\$400.00/LF) when compared with a Bid Tab analysis of bid prices for the item from December 2024 to April 2026. Unit price DOES NOT include Prime Contractor markup of 10% per 1109.03,3.

E-contract time adjustment

None. This change has no impact on the controlling item of work.

New Items

Line Number	Item ID	Unit	Quantity	Unit Price	Extension
Section: 0001 - STP-U-7662(615)--70-52, ROADWAY ITEMS					
8220	2503-0111018	LF	20.000	\$62.500	\$1,250.00
STORM SEWER GRAVITY MAIN, TRENCHED, HIGH DENSITY POLYETHYLENE PIPE (HDPE), 18 IN.					
			Funding Details		
		52-7662-615-CAT-3 NON-PARTICIPATING	20.000	\$62.500	\$1,250.00
1 item					Total: \$1,250.00

Funding Summary

Fund Package	Original Amount	Authorized Amount	Pending Change	Revised Amount
52-7662-615-CAT-1 ROADWAY ITEMS	\$4,872,701.91	\$4,866,768.26	\$0.00	\$4,866,768.26

Fund Package	Original Amount	Authorized Amount	Pending Change	Revised Amount
52-7662-615-CAT-2 ROADWAY ITEMS - DIVISION 2	\$586,190.00	\$687,681.15	\$0.00	\$687,681.15
52-7662-615-CAT-3 NON-PARTICIPATING	\$0.00	\$0.00	\$1,250.00	\$1,250.00
3 fund packages	\$5,458,891.91	\$5,554,449.41	\$1,250.00	\$5,555,699.41

Attachments

Document	Name	Description	Submission Date
24060_-_RFC__013_-_CO__15_-_18_Culv_Pipe.pdf	24060 - RFC #013 - CO #15 - 18 Culv Pipe.pdf		04/23/2026 04:07 PM EDT
bid_ex_justification.jpg	bid ex justification.jpg		04/23/2026 04:07 PM EDT
2 attachments			

Doc Express® Document Signing History

Contract: 52-7662-615 Document: change_order-15-20260423

This document is in the process of being signed by all required signatories using the Doc Express® service. Following are the signatures that have occurred so far.

Date	Signed By
04/24/2026	Dakota Simonsen Boomerang Corp. Electronic Signature (Approved by Contractor)
04/27/2026	James Watters MSA Professional Svs Electronic Signature (Recommended by Engineer / Approved)
	(Approved by PIRC (when applicable))
	(Approved by Administering Bureau or designee)
	(Approved by FHWA (when applicable))



AGENDA INFORMATION
TIFFIN CITY COUNCIL COMMUNICATION

DATE:	May 1, 2026
AGENDA ITEM:	Discussion and Consideration of Pay Application #12– Boomerang Corporation, North Park Road Improvements Project
ACTION:	Motion

Background

The City entered into a construction contract with Boomerang Corporation for the North Park Road Improvements project following the December 17, 2024 letting. The project includes roadway reconstruction, storm sewer improvements, water main installation, pedestrian facilities, and related infrastructure upgrades.

Pay applications are submitted periodically based on progress and quantities installed and are reviewed by City staff and the project engineer prior to Council approval.

Pay Application No. 12 represents progress billing for roadway, storm sewer, water main, and associated infrastructure work completed during the pay period of March 29, 2026 through April 25, 2026. The pay application has been reviewed and recommended for approval by the project engineer.

Pay Application Details:

- **Payment Number:** 12
- **Pay Period:** March 29, 2026 – April 25, 2026
- **Current Payment Amount:** \$456,453.50
- **Engineer Recommendation Date:** April 30, 2026

Work during this period includes, but is not limited to: Storm sewer installation and structure work, Water main installation and fittings, Roadway grading and excavation, Traffic control and erosion control measures, and miscellaneous concrete and utility-related work.

The payment includes eligible participating roadway items and Division II items, with no non-participating costs included in this application.

Staff Recommendation

Staff recommends approval of Pay Application No. 12 to Boomerang Corporation in the amount of \$456,453.50 for the North Park Road Improvements project.

ATTACHMENTS: Pay Application



City of Tiffin - Iowa

Detailed Payment

52-7662-615

Description	STP-U-7662(615)--70-52, Letting Date- December 17, 2024
Payment Number	12
Pay Period	03/29/2026 to 04/25/2026
Approval Date	05/05/2026
Prime Contractor	Boomerang Corp. 13225 Circle Dr Suite A, Anamosa, IA 52205 Anamosa, IA, IA 52205
Payment Status	Pending
Awarded Project Amount	\$5,458,891.91
Authorized Amount	\$5,554,449.41

Line Number	Item ID	Unit	Unit Price	Authorized Quantity	Current Paid Quantity	Previous Paid Quantity	Total Quantity Paid To Date	Total Quantity Placed To Date	Current Payment Amount	Total Amount Paid To Date
Section: 0001 - STP-U-7662(615)--70-52, ROADWAY ITEMS										
0010	2101-0850001	ACRE	\$12,000.000	1.235	0.000	1.120	1.120	1.120	\$0.00	\$13,440.00
CLEARING AND GRUBBING										
0020	2102-2625001	CY	\$15.000	13,760.000	0.000	10,455.000	10,455.000	10,455.000	\$0.00	\$156,825.00
EMBANKMENT-IN-PLACE, CONTRACTOR FURNISHED										

Line Number	Item ID	Unit	Unit Price	Authorized Quantity	Current Paid Quantity	Previous Paid Quantity	Total Quantity Paid To Date	Total Quantity Placed To Date	Current Payment Amount	Total Amount Paid To Date
0030	2102-2710070	CY	\$5.000	19,798.000	0.000	19,286.740	19,286.740	19,286.740	\$0.00	\$96,433.70
EXCAVATION, CLASS 10, ROADWAY AND BORROW										
0040	2105-8425015	CY	\$4.000	13,235.000	0.000	9,680.000	9,680.000	9,680.000	\$0.00	\$38,720.00
TOPSOIL, STRIP, SALVAGE AND SPREAD										
0050	2107-0425020	CY	\$1.000	191.000	100.000	91.000	191.000	191.000	\$100.00	\$191.00
COMPACTING BACKFILL ADJACENT TO BRIDGES, CULVERTS OR STRUCTURES										
0060	2109-8225100	STA	\$480.000	67.700	0.000	28.960	28.960	28.960	\$0.00	\$13,900.80
SPECIAL COMPACTION OF SUBGRADE										
0070	2111-8174100	SY	\$15.000	1,707.000	0.000	1,411.000	1,411.000	1,411.000	\$0.00	\$21,165.00
GRANULAR SUBBASE										
0080	2115-0100000	CY	\$43.000	4,691.000	0.000	3,605.880	3,605.880	3,605.880	\$0.00	\$155,052.84
MODIFIED SUBBASE										
0090	2123-7450020	STA	\$520.000	68.200	0.000	31.000	31.000	31.000	\$0.00	\$16,120.00
SHOULDER FINISHING, EARTH										
0100	2213-7100400	EACH	\$750.000	1.000	0.000	0.000	0.000	0.000	\$0.00	\$0.00
RELOCATION OF MAIL BOXES										
0110	2301-1033090	SY	\$54.000	23,371.300	0.000	12,007.240	12,007.240	12,007.240	\$0.00	\$648,390.96
STANDARD OR SLIP FORM PORTLAND CEMENT CONCRETE PAVEMENT, CLASS C, CLASS 3 DURABILITY, 9 IN.										
0120	2301-1033140	SY	\$90.000	480.700	0.000	480.700	480.700	480.700	\$0.00	\$43,263.00
STANDARD OR SLIP FORM PORTLAND CEMENT CONCRETE PAVEMENT, CLASS C, CLASS 3 DURABILITY, 14 IN.										

Line Number	Item ID	Unit	Unit Price	Authorized Quantity	Current Paid Quantity	Previous Paid Quantity	Total Quantity Paid To Date	Total Quantity Placed To Date	Current Payment Amount	Total Amount Paid To Date
0130	2301-4875006	SY	\$43.000	3,479.300	0.000	1,995.050	1,995.050	1,995.050	\$0.00	\$85,787.15
MEDIAN, P.C. CONCRETE, 6 IN.										
0140	2301-6911722	LS	\$2,000.000	1.000	0.000	0.420	0.420	0.420	\$0.00	\$840.00
PORTLAND CEMENT CONCRETE PAVEMENT SAMPLES										
0141	2301-7000110	EACH	\$1.000	27,758.800	0.000	0.000	0.000	0.000	\$0.00	\$0.00
PAYMENT ADJUSTMENT INCENTIVE/DISINCENTIVE FOR PCC PAVEMENT THICKNESS (BY SCHEDULE)										
0150	2304-0101000	SY	\$70.000	2,158.000	0.000	546.000	546.000	546.000	\$0.00	\$38,220.00
TEMPORARY PAVEMENT										
0160	2310-5151040	CY	\$150.000	17.000	0.000	0.000	0.000	0.000	\$0.00	\$0.00
PORTLAND CEMENT CONCRETE OVERLAY, FURNISH ONLY										
0170	2310-5151045	SY	\$12.000	299.000	0.000	0.000	0.000	0.000	\$0.00	\$0.00
PORTLAND CEMENT CONCRETE OVERLAY, PLACEMENT ONLY										
0180	2401-6745650	LS	\$8,800.000	1.000	1.000	0.000	1.000	1.000	\$8,800.00	\$8,800.00
REMOVAL OF EXISTING STRUCTURES										
0190	2402-0425030	CY	\$48.000	1,351.000	765.000	586.000	1,351.000	1,351.000	\$36,720.00	\$64,848.00
GRANULAR BACKFILL										
0200	2402-0425040	CY	\$70.000	44.000	44.000	0.000	44.000	44.000	\$3,080.00	\$3,080.00
FLOODED BACKFILL										
0210	2402-2720000	CY	\$4.000	5,741.000	0.000	5,741.000	5,741.000	5,741.000	\$0.00	\$22,964.00
EXCAVATION, CLASS 20										

Line Number	Item ID	Unit	Unit Price	Authorized Quantity	Current Paid Quantity	Previous Paid Quantity	Total Quantity Paid To Date	Total Quantity Placed To Date	Current Payment Amount	Total Amount Paid To Date
0220	2402-2720100	CY	\$4.000	610.000	610.000	0.000	610.000	610.000	\$2,440.00	\$2,440.00
EXCAVATION, CLASS 20, FOR ROADWAY PIPE CULVERT										
0230	2403-0100020	CY	\$840.000	149.400	0.000	149.400	149.400	149.400	\$0.00	\$125,496.00
STRUCTURAL CONCRETE (RCB CULVERT)										
0240	2403-7303000	SY	\$27.500	901.000	0.000	0.000	0.000	0.000	\$0.00	\$0.00
STRUCTURAL CONCRETE COATING										
0250	2404-7775000	LB	\$2.300	21,166.000	0.000	21,166.000	21,166.000	21,166.000	\$0.00	\$48,681.80
REINFORCING STEEL										
0260	2414-6444100	LF	\$200.000	168.000	0.000	168.000	168.000	168.000	\$0.00	\$33,600.00
STEEL PIPE PEDESTRIAN HAND RAILING										
0270	2415-2151212	LF	\$2,000.000	224.000	0.000	224.000	224.000	224.000	\$0.00	\$448,000.00
PRECAST REINFORCED CONCRETE PEDESTRIAN TUNNEL, 12 FT. X 12 FT.										
0280	2416-0100030	EACH	\$3,800.000	1.000	0.000	1.000	1.000	1.000	\$0.00	\$3,800.00
APRONS, CONCRETE, 30 IN. DIA.										
0290	2416-0100042	EACH	\$4,400.000	1.000	1.000	0.000	1.000	1.000	\$4,400.00	\$4,400.00
APRONS, CONCRETE, 42 IN. DIA.										
0300	2416-0100072	EACH	\$7,200.000	1.000	1.000	0.000	1.000	1.000	\$7,200.00	\$7,200.00
APRONS, CONCRETE, 72 IN. DIA.										
0310	2416-1180072	LF	\$400.000	339.000	339.000	0.000	339.000	339.000	\$135,600.00	\$135,600.00
CULVERT, CONCRETE ROADWAY PIPE, 72 IN. DIA.										

Line Number	Item ID	Unit	Unit Price	Authorized Quantity	Current Paid Quantity	Previous Paid Quantity	Total Quantity Paid To Date	Total Quantity Placed To Date	Current Payment Amount	Total Amount Paid To Date
0320	2435-0140148	EACH	\$7,000.000	2.000	0.000	2.000	2.000	2.000	\$0.00	\$14,000.00
MANHOLE, STORM SEWER, SW-401, 48 IN.										
0330	2435-0140160	EACH	\$8,000.000	8.000	0.000	8.000	8.000	8.000	\$0.00	\$64,000.00
MANHOLE, STORM SEWER, SW-401, 60 IN.										
0340	2435-0140310	EACH	\$20,000.000	0.000	0.000	0.000	0.000	0.000	\$0.00	\$0.00
MANHOLE, STORM SEWER, SW-403 MODIFIED										
0341	2435-0250248	EACH	\$7,000.000	1.000	0.000	1.000	1.000	1.000	\$0.00	\$7,000.00
INTAKE, SW-502, 48 IN.										
0342	2435-0250260	EACH	\$8,400.000	4.000	0.000	4.000	4.000	4.000	\$0.00	\$33,600.00
INTAKE, SW-502, 60 IN.										
0350	2435-0250700	EACH	\$6,400.000	2.000	0.000	2.000	2.000	2.000	\$0.00	\$12,800.00
INTAKE, SW-507										
0360	2435-0250900	EACH	\$8,500.000	16.000	10.000	3.000	13.000	13.000	\$85,000.00	\$110,500.00
INTAKE, SW-509										
0370	2435-0251000	EACH	\$11,000.000	4.000	2.000	2.000	4.000	4.000	\$22,000.00	\$44,000.00
INTAKE, SW-510										
0380	2435-0251224	EACH	\$2,200.000	2.000	0.000	2.000	2.000	2.000	\$0.00	\$4,400.00
INTAKE, SW-512, 24 IN.										
0390	2435-0251300	EACH	\$5,300.000	1.000	1.000	0.000	1.000	1.000	\$5,300.00	\$5,300.00
INTAKE, SW-513										

Line Number	Item ID	Unit	Unit Price	Authorized Quantity	Current Paid Quantity	Previous Paid Quantity	Total Quantity Paid To Date	Total Quantity Placed To Date	Current Payment Amount	Total Amount Paid To Date
0400	2435-0600010	EACH	\$2,800.000	5.000	0.000	1.000	1.000	1.000	\$0.00	\$2,800.00
MANHOLE ADJUSTMENT, MINOR										
0410	2435-0600020	EACH	\$4,000.000	7.000	0.000	6.000	6.000	6.000	\$0.00	\$24,000.00
MANHOLE ADJUSTMENT, MAJOR										
0420	2435-0600110	EACH	\$3,200.000	2.000	0.000	1.000	1.000	1.000	\$0.00	\$3,200.00
INTAKE ADJUSTMENT, MINOR										
0430	2502-8212036	LF	\$15.500	6,106.700	60.000	4,014.000	4,074.000	4,074.000	\$930.00	\$63,147.00
SUBDRAIN, LONGITUDINAL, (SHOULDER) 6 IN. DIA.										
0440	2502-8221006	EACH	\$1,200.000	6.000	0.000	3.000	3.000	3.000	\$0.00	\$3,600.00
SUBDRAIN RISER, 6 IN., AS PER PLAN										
0450	2502-8221303	EACH	\$320.000	24.000	1.000	22.000	23.000	23.000	\$320.00	\$7,360.00
SUBDRAIN OUTLET, DR-303										
0460	2503-0114215	LF	\$70.000	587.000	116.000	391.000	507.000	507.000	\$8,120.00	\$35,490.00
STORM SEWER GRAVITY MAIN, TRENCHED, REINFORCED CONCRETE PIPE (RCP), 2000D (CLASS III), 15 IN.										
0470	2503-0114218	LF	\$80.000	718.000	375.000	261.000	636.000	636.000	\$30,000.00	\$50,880.00
STORM SEWER GRAVITY MAIN, TRENCHED, REINFORCED CONCRETE PIPE (RCP), 2000D (CLASS III), 18 IN.										
0480	2503-0114221	LF	\$170.000	0.000	0.000	0.000	0.000	0.000	\$0.00	\$0.00
STORM SEWER GRAVITY MAIN, TRENCHED, REINFORCED CONCRETE PIPE (RCP), 2000D (CLASS III), 21 IN.										
0490	2503-0114224	LF	\$90.000	247.000	172.000	43.000	215.000	215.000	\$15,480.00	\$19,350.00
STORM SEWER GRAVITY MAIN, TRENCHED, REINFORCED CONCRETE PIPE (RCP), 2000D (CLASS III), 24 IN.										

Line Number	Item ID	Unit	Unit Price	Authorized Quantity	Current Paid Quantity	Previous Paid Quantity	Total Quantity Paid To Date	Total Quantity Placed To Date	Current Payment Amount	Total Amount Paid To Date
0500	2503-0114227	LF	\$100.000	169.000	0.000	169.000	169.000	169.000	\$0.00	\$16,900.00
STORM SEWER GRAVITY MAIN, TRENCHED, REINFORCED CONCRETE PIPE (RCP), 2000D (CLASS III), 27 IN.										
0510	2503-0114230	LF	\$120.000	588.000	24.000	588.000	612.000	612.000	\$2,880.00	\$73,440.00
STORM SEWER GRAVITY MAIN, TRENCHED, REINFORCED CONCRETE PIPE (RCP), 2000D (CLASS III), 30 IN.										
0520	2503-0114236	LF	\$140.000	29.000	29.000	0.000	29.000	29.000	\$4,060.00	\$4,060.00
STORM SEWER GRAVITY MAIN, TRENCHED, REINFORCED CONCRETE PIPE (RCP), 2000D (CLASS III), 36 IN.										
0530	2503-0114242	LF	\$200.000	136.000	136.000	0.000	136.000	136.000	\$27,200.00	\$27,200.00
STORM SEWER GRAVITY MAIN, TRENCHED, REINFORCED CONCRETE PIPE (RCP), 2000D (CLASS III), 42 IN.										
0540	2503-0114424	LF	\$150.000	235.000	0.000	235.000	235.000	235.000	\$0.00	\$35,250.00
STORM SEWER GRAVITY MAIN, TRENCHED, REINFORCED CONCRETE PIPE (RCP), 3000D (CLASS IV), 24 IN.										
0550	2503-0114615	LF	\$130.000	330.000	0.000	330.000	330.000	330.000	\$0.00	\$42,900.00
STORM SEWER GRAVITY MAIN, TRENCHED, REINFORCED CONCRETE PIPE (RCP), 3750D (CLASS V), 15 IN.										
0560	2503-0114621	LF	\$150.000	311.000	0.000	311.000	311.000	311.000	\$0.00	\$46,650.00
STORM SEWER GRAVITY MAIN, TRENCHED, REINFORCED CONCRETE PIPE (RCP), 3750D (CLASS V), 21 IN.										
0570	2503-0200036	LF	\$10.000	682.000	111.000	356.000	467.000	467.000	\$1,110.00	\$4,670.00
REMOVE STORM SEWER PIPE LESS THAN OR EQUAL TO 36 IN.										
0580	2503-0200136	LF	\$30.000	16.000	0.000	0.000	0.000	0.000	\$0.00	\$0.00
REMOVE STORM SEWER PIPE GREATER THAN 36 IN.										
0590	2505-4008120	LF	\$6.000	468.600	0.000	468.600	468.600	468.600	\$0.00	\$2,811.60
REMOVAL OF STEEL BEAM GUARDRAIL										

Line Number	Item ID	Unit	Unit Price	Authorized Quantity	Current Paid Quantity	Previous Paid Quantity	Total Quantity Paid To Date	Total Quantity Placed To Date	Current Payment Amount	Total Amount Paid To Date
0600	2507-3250005	SY	\$1.000	53.000	0.000	0.000	0.000	0.000	\$0.00	\$0.00
ENGINEERING FABRIC										
0610	2507-6800032	TON	\$90.000	53.000	0.000	19.660	19.660	19.660	\$0.00	\$1,769.40
REVTMENT, CLASS C										
0620	2510-6745850	SY	\$6.000	12,296.200	0.000	10,008.400	10,008.400	10,008.400	\$0.00	\$60,050.40
REMOVAL OF PAVEMENT										
0630	2510-6750600	EACH	\$500.000	3.000	1.000	3.000	4.000	4.000	\$500.00	\$2,000.00
REMOVAL OF INTAKES AND UTILITY ACCESSES										
0640	2511-0302600	SY	\$44.000	3,837.500	0.000	893.960	893.960	893.960	\$0.00	\$39,334.24
RECREATIONAL TRAIL, PORTLAND CEMENT CONCRETE, 6 IN.										
0650	2511-0310100	STA	\$200.000	32.000	0.000	15.500	15.500	15.500	\$0.00	\$3,100.00
SPECIAL COMPACTION OF SUBGRADE FOR RECREATIONAL TRAIL										
0660	2511-7526004	SY	\$42.000	1,702.000	0.000	0.000	0.000	0.000	\$0.00	\$0.00
SIDEWALK, P.C. CONCRETE, 4 IN.										
0670	2511-7526006	SY	\$64.000	145.100	0.000	37.150	37.150	37.150	\$0.00	\$2,377.60
SIDEWALK, P.C. CONCRETE, 6 IN.										
0680	2511-7528101	SF	\$50.000	292.400	0.000	44.000	44.000	44.000	\$0.00	\$2,200.00
DETECTABLE WARNINGS										
0690	2512-1725306	LF	\$25.000	1,189.400	0.000	540.130	540.130	540.130	\$0.00	\$13,503.25
CURB AND GUTTER, P.C. CONCRETE, 3.0 FT.										

Line Number	Item ID	Unit	Unit Price	Authorized Quantity	Current Paid Quantity	Previous Paid Quantity	Total Quantity Paid To Date	Total Quantity Placed To Date	Current Payment Amount	Total Amount Paid To Date
0700	2515-2475006	SY	\$56.000	108.100	0.000	0.000	0.000	0.000	\$0.00	\$0.00
DRIVEWAY, P.C. CONCRETE, 6 IN.										
0710	2515-6745600	SY	\$10.000	562.200	0.000	345.400	345.400	345.400	\$0.00	\$3,454.00
REMOVAL OF PAVED DRIVEWAY										
0720	2519-4200110	LF	\$5.000	1,843.800	0.000	1,843.800	1,843.800	1,843.800	\$0.00	\$9,219.00
REMOVAL OF FENCE, BARBED WIRE										
0730	2524-6765010	EACH	\$275.000	16.000	0.000	8.000	8.000	8.000	\$0.00	\$2,200.00
REMOVE AND REINSTALL SIGN AS PER PLAN										
0740	2524-6765210	EACH	\$125.000	20.000	0.000	10.000	10.000	10.000	\$0.00	\$1,250.00
REMOVAL OF TYPE A SIGN ASSEMBLY										
0750	2524-9100010	EACH	\$275.000	6.000	0.000	0.000	0.000	0.000	\$0.00	\$0.00
OBJECT MARKER, TYPE 1										
0760	2524-9276010	LF	\$16.000	569.000	0.000	402.000	402.000	402.000	\$0.00	\$6,432.00
PERFORATED SQUARE STEEL TUBE POSTS										
0770	2524-9276021	EACH	\$125.000	30.000	0.000	19.000	19.000	19.000	\$0.00	\$2,375.00
PERFORATED SQUARE STEEL TUBE POST ANCHOR, BREAK-AWAY SOIL INSTALLATION										
0780	2524-9276024	EACH	\$275.000	11.000	0.000	10.000	10.000	10.000	\$0.00	\$2,750.00
PERFORATED SQUARE STEEL TUBE POST ANCHOR, BREAK-AWAY CONCRETE INSTALLATION										
0790	2524-9276027	EACH	\$525.000	2.000	0.000	2.000	2.000	2.000	\$0.00	\$1,050.00
PERFORATED SQUARE STEEL TUBE POST ANCHOR, TRIANGULAR SLIP BASE ASSEMBLY										

Line Number	Item ID	Unit	Unit Price	Authorized Quantity	Current Paid Quantity	Previous Paid Quantity	Total Quantity Paid To Date	Total Quantity Placed To Date	Current Payment Amount	Total Amount Paid To Date
0800	2524-9325001	SF	\$22.000	268.200	0.000	200.000	200.000	200.000	\$0.00	\$4,400.00
TYPE A SIGNS, SHEET ALUMINUM										
0810	2526-8285000	LS	\$50,000.000	1.000	0.000	0.700	0.700	0.700	\$0.00	\$35,000.00
CONSTRUCTION SURVEY										
0820	2527-9263137	EACH	\$155.000	18.000	0.000	12.000	12.000	12.000	\$0.00	\$1,860.00
PAINTED SYMBOLS AND LEGENDS, WATERBORNE OR SOLVENT-BASED										
0830	2527-9263209	STA	\$105.000	61.450	0.000	54.860	54.860	54.860	\$0.00	\$5,760.30
PAINTED PAVEMENT MARKINGS, WATERBORNE OR SOLVENT-BASED										
0840	2528-2518000	EACH	\$250.000	23.000	0.000	3.000	3.000	3.000	\$0.00	\$750.00
SAFETY CLOSURE										
0850	2528-2518182	EACH	\$1,800.000	1.000	0.000	0.000	0.000	0.000	\$0.00	\$0.00
PERMANENT ROAD CLOSURE, URBAN, SI-182										
0860	2528-8445110	LS	\$27,000.000	1.000	0.000	0.700	0.700	0.700	\$0.00	\$18,900.00
TRAFFIC CONTROL										
0870	2533-4980005	LS	\$41,000.000	1.000	0.000	1.000	1.000	1.000	\$0.00	\$41,000.00
MOBILIZATION										
0880	2552-0000300	LS	\$12,000.000	1.000	0.000	0.400	0.400	0.400	\$0.00	\$4,800.00
TRENCH COMPACTION TESTING										
0890	2554-0114006	LF	\$200.000	5.000	0.000	52.750	52.750	52.750	\$0.00	\$10,550.00
WATER MAIN, TRENCHED, POLYVINYL CHLORIDE PIPE (PVC), 6 IN.										

Line Number	Item ID	Unit	Unit Price	Authorized Quantity	Current Paid Quantity	Previous Paid Quantity	Total Quantity Paid To Date	Total Quantity Placed To Date	Current Payment Amount	Total Amount Paid To Date
0900	2554-0114008	LF	\$50.000	252.000	20.000	60.000	80.000	80.000	\$1,000.00	\$4,000.00
WATER MAIN, TRENCHED, POLYVINYL CHLORIDE PIPE (PVC), 8 IN.										
0910	2554-0114012	LF	\$70.000	3,060.000	40.000	3,060.250	3,100.250	3,100.250	\$2,800.00	\$217,017.50
WATER MAIN, TRENCHED, POLYVINYL CHLORIDE PIPE (PVC), 12 IN.										
0920	2554-0203000	LB	\$16.000	3,280.000	544.000	2,262.000	2,806.000	2,806.000	\$8,704.00	\$44,896.00
FITTINGS BY WEIGHT, DUCTILE IRON										
0930	2554-0204110	EACH	\$3,200.000	1.000	0.000	0.000	0.000	0.000	\$0.00	\$0.00
WATER SERVICE STUB, COPPER, 1 IN.										
0940	2554-0204120	EACH	\$3,600.000	0.000	0.000	0.000	0.000	0.000	\$0.00	\$0.00
WATER SERVICE STUB, COPPER, 2 IN.										
0950	2554-0207008	EACH	\$4,000.000	1.000	0.000	1.000	1.000	1.000	\$0.00	\$4,000.00
VALVE, GATE, DIP, 8 IN.										
0960	2554-0207012	EACH	\$6,600.000	15.000	0.000	15.000	15.000	15.000	\$0.00	\$99,000.00
VALVE, GATE, DIP, 12 IN.										
0970	2554-0209012	EACH	\$250.000	6.000	0.000	4.000	4.000	4.000	\$0.00	\$1,000.00
VALVE REMOVAL, 12 IN.										
0980	2554-0210201	EACH	\$12,000.000	10.000	0.000	10.000	10.000	10.000	\$0.00	\$120,000.00
FIRE HYDRANT ASSEMBLY, WM-201										
0990	2554-0210205	EACH	\$250.000	3.000	0.000	4.000	4.000	4.000	\$0.00	\$1,000.00
FIRE HYDRANT ASSEMBLY REMOVAL										

Line Number	Item ID	Unit	Unit Price	Authorized Quantity	Current Paid Quantity	Previous Paid Quantity	Total Quantity Paid To Date	Total Quantity Placed To Date	Current Payment Amount	Total Amount Paid To Date
1000	2554-0211002	EACH	\$2,200.000	4.000	1.000	4.000	5.000	5.000	\$2,200.00	\$11,000.00
FLUSHING DEVICE (BLOWOFF), 2 IN.										
1010	2555-0000010	LS	\$2,400.000	1.000	0.000	0.000	0.000	0.000	\$0.00	\$0.00
DELIVER AND STOCKPILE SALVAGED MATERIALS										
1020	2599-9999005	EACH	\$1,500.000	4.000	2.000	2.000	4.000	4.000	\$3,000.00	\$6,000.00
('EACH' ITEM): CONNECTION TO EXISTING WATER MAIN										
1030	2599-9999009	LF	\$4.000	655.000	0.000	655.000	655.000	655.000	\$0.00	\$2,620.00
('LINEAR FEET' ITEM): FILL, PLUG, AND ABANDONMENT OF EXISTING WATER MAIN										
1040	2599-9999010	LS	\$30,000.000	1.000	0.000	0.000	0.000	0.000	\$0.00	\$0.00
('LUMP SUM' ITEM): PEDESTRIAN UNDERPASS LIGHTING SYSTEM										
1050	2599-9999010	LS	\$116,000.000	0.000	0.000	0.000	0.000	0.000	\$0.00	\$0.00
('LUMP SUM' ITEM): ROUNDABOUT LIGHTING SYSTEM										
1060	2599-9999018	SY	\$17.500	1,035.000	0.000	0.000	0.000	0.000	\$0.00	\$0.00
('SQUARE YARDS' ITEM): ANTI-GRAFFITI COATING										
1070	2601-2634105	ACRE	\$2,950.000	7.290	1.300	13.340	14.640	14.640	\$3,835.00	\$43,188.00
MULCHING, BONDED FIBER MATRIX										
1080	2601-2636044	ACRE	\$1,480.000	7.290	0.000	1.040	1.040	1.040	\$0.00	\$1,539.20
SEEDING AND FERTILIZING (URBAN)										
1090	2601-2638352	SQ	\$16.000	65.000	0.000	48.000	48.000	48.000	\$0.00	\$768.00
SLOPE PROTECTION, WOOD EXCELSIOR MAT										

Line Number	Item ID	Unit	Unit Price	Authorized Quantity	Current Paid Quantity	Previous Paid Quantity	Total Quantity Paid To Date	Total Quantity Placed To Date	Current Payment Amount	Total Amount Paid To Date
1100	2601-2643110	MGAL	\$75.000	13.000	0.000	0.000	0.000	0.000	\$0.00	\$0.00
WATERING FOR SOD, SPECIAL DITCH CONTROL, OR SLOPE PROTECTION										
1110	2601-2643300	EACH	\$450.000	4.000	0.000	0.000	0.000	0.000	\$0.00	\$0.00
MOBILIZATION FOR WATERING										
1120	2602-0000020	LF	\$1.650	11,745.000	138.000	3,796.000	3,934.000	3,934.000	\$227.70	\$6,491.10
SILT FENCE										
1130	2602-0000071	LF	\$0.050	1,174.500	0.000	0.000	0.000	0.000	\$0.00	\$0.00
REMOVAL OF SILT FENCE OR SILT FENCE FOR DITCH CHECKS										
1140	2602-0000101	LF	\$0.050	5,872.500	0.000	0.000	0.000	0.000	\$0.00	\$0.00
MAINTENANCE OF SILT FENCE OR SILT FENCE FOR DITCH CHECK										
1150	2602-0000309	LF	\$3.400	725.000	222.000	5,915.000	6,137.000	6,137.000	\$754.80	\$20,865.80
PERIMETER AND SLOPE SEDIMENT CONTROL DEVICE, 9 IN. DIA.										
1160	2602-0000351	LF	\$0.500	725.000	0.000	130.000	130.000	130.000	\$0.00	\$65.00
REMOVAL OF PERIMETER AND SLOPE OR DITCH CHECK SEDIMENT CONTROL DEVICE										
1170	2602-0000500	LF	\$13.500	261.000	0.000	56.000	56.000	56.000	\$0.00	\$756.00
OPEN-THROAT CURB INTAKE SEDIMENT FILTER, EC-602										
1180	2602-0000510	EACH	\$5.000	29.000	0.000	16.000	16.000	16.000	\$0.00	\$80.00
MAINTENANCE OF OPEN-THROAT CURB INTAKE SEDIMENT FILTER										
1190	2602-0000520	EACH	\$5.000	29.000	0.000	0.000	0.000	0.000	\$0.00	\$0.00
REMOVAL OF OPEN-THROAT CURB INTAKE SEDIMENT FILTER										

Line Number	Item ID	Unit	Unit Price	Authorized Quantity	Current Paid Quantity	Previous Paid Quantity	Total Quantity Paid To Date	Total Quantity Placed To Date	Current Payment Amount	Total Amount Paid To Date
1200	2602-0010010	EACH	\$600.000	1.000	3.000	23.000	26.000	26.000	\$1,800.00	\$15,600.00
MOBILIZATIONS, EROSION CONTROL										
1210	2602-0010020	EACH	\$1,200.000	1.000	0.000	1.000	1.000	1.000	\$0.00	\$1,200.00
MOBILIZATIONS, EMERGENCY EROSION CONTROL										
8000	8000-0000000	None	\$0.000	0.000	0.000	0.000	0.000	0.000	\$0.00	\$0.00
PLACEHOLDER ONLY (DO NOT USE)										
8010	2601-2642100	ACRE	\$825.000	7.290	0.000	10.500	10.500	10.500	\$0.00	\$8,662.50
STABILIZING CROP - SEEDING AND FERTILIZING										
8020	2528-8445110	LS	\$1.000	1,980.000	0.000	1,980.000	1,980.000	1,980.000	\$0.00	\$1,980.00
TRAFFIC CONTROL										
8030	2602-0000030	LF	\$3.000	200.000	474.000	162.000	636.000	636.000	\$1,422.00	\$1,908.00
SILT FENCE FOR DITCH CHECKS										
8040	2506-4984000	CY	\$1,650.000	1.000	0.000	3.000	3.000	3.000	\$0.00	\$4,950.00
FLOWABLE MORTAR										
8050	2523-0000200	LF	\$22.000	30.000	0.000	30.000	30.000	30.000	\$0.00	\$660.00
ELECTRICAL CIRCUITS										
8060	2523-0000100	EACH	\$3,520.000	1.000	0.000	1.000	1.000	1.000	\$0.00	\$3,520.00
LIGHTING POLES										
8070	2599-9999005	EACH	\$3,650.000	1.000	0.500	0.500	1.000	1.000	\$1,825.00	\$3,650.00
('EACH' ITEM): RELOCATE WATER SAMPLING STATION										

Line Number	Item ID	Unit	Unit Price	Authorized Quantity	Current Paid Quantity	Previous Paid Quantity	Total Quantity Paid To Date	Total Quantity Placed To Date	Current Payment Amount	Total Amount Paid To Date
8080	2599-9999010	LS	\$116,000.000	1.000	0.000	1.000	1.000	1.000	\$0.00	\$116,000.00
('LUMP SUM' ITEM): ROUNDABOUT LIGHTING SYSTEM										
8090	2602-0000530	EACH	\$192.500	5.000	0.000	5.000	5.000	5.000	\$0.00	\$962.50
GRATE INTAKE SEDIMENT FILTER BAG, EC-604										
8100	2602-0000540	EACH	\$5.500	5.000	0.000	8.000	8.000	8.000	\$0.00	\$44.00
MAINTENANCE OF GRATE INTAKE SEDIMENT FILTER BAG										
8110	2602-0000550	EACH	\$5.500	5.000	0.000	0.000	0.000	0.000	\$0.00	\$0.00
REMOVAL OF GRATE INTAKE SEDIMENT FILTER BAG										
8120	2528-8400048	LF	\$99.000	50.000	0.000	50.000	50.000	50.000	\$0.00	\$4,950.00
TEMPORARY BARRIER RAIL, CONCRETE										
8130	2602-0000160	LF	\$55.000	200.000	0.000	135.000	135.000	135.000	\$0.00	\$7,425.00
ROCK CHECK DAM										
8140	2602-0000170	EACH	\$350.000	5.000	0.000	2.000	2.000	2.000	\$0.00	\$700.00
MAINTENANCE OF ROCK CHECK DAM										
8150	2602-0000180	EACH	\$400.000	5.000	0.000	0.000	0.000	0.000	\$0.00	\$0.00
REMOVAL OF ROCK CHECK DAM										
8160	6100-2528035	EACH	\$2,750.000	1.000	0.000	1.000	1.000	1.000	\$0.00	\$2,750.00
{EXTRA WORK} TRAFFIC CONTROL										
8170	2435-0140310	EACH	\$46,500.000	1.000	0.000	0.000	0.000	0.000	\$0.00	\$0.00
MANHOLE, STORM SEWER, SW-403 MODIFIED										

Line Number	Item ID	Unit	Unit Price	Authorized Quantity	Current Paid Quantity	Previous Paid Quantity	Total Quantity Paid To Date	Total Quantity Placed To Date	Current Payment Amount	Total Amount Paid To Date
8180	2554-0114010	LF	\$65.000	233.000	233.000	0.000	233.000	233.000	\$15,145.00	\$15,145.00
WATER MAIN, TRENCHED, POLYVINYL CHLORIDE PIPE (PVC), 10 IN.										
8190	2554-0207010	EACH	\$6,250.000	2.000	2.000	0.000	2.000	2.000	\$12,500.00	\$12,500.00
VALVE, GATE, DIP, 10 IN.										
8200	2435-0250902	EACH	\$1,796.850	1.000	0.000	0.000	0.000	0.000	\$0.00	\$0.00
INTAKE, SW-509, WELL ONLY										
8210	2599-9999005	EACH	\$2,117.500	1.000	0.000	0.000	0.000	0.000	\$0.00	\$0.00
('EACH' ITEM): MANHOLE, STORM SEWER, SW-401, 60 IN., WELL ONLY										
8220	2503-0111018	LF	\$0.000	0.000	0.000	0.000	0.000	0.000	\$0.00	\$0.00
STORM SEWER GRAVITY MAIN, TRENCHED, HIGH DENSITY POLYETHYLENE PIPE (HDPE), 18 IN.										
Section Totals:									\$456,453.50	\$4,059,546.64
Total Payments:									\$456,453.50	\$4,059,546.64

Time Charges

Time Limit	Original Deadline	Authorized Deadline	Charges This Period	Damages This Period	Days Completed To Date	Days Remaining To Date	Damages To Date
Working Days, Late Start Date - 04/07/2025, Liquidated Damage Rate - 2,000	200.0 Days	208.0 Days	9.0 Days	\$0.00	95.5 Days	112.5 Days	\$0.00
Total Damages:							\$0.00

Stockpiles

Stockpile	Fund Package	Current Advancements	Advancements To Date	Current Recoveries	Recoveries To Date
#1 - 2435-0250700 INTAKE, SW-507	52-7662-615-CAT-1 ROADWAY ITEMS	\$0.00	\$1,224.30	\$0.00	\$1,224.30
#2 - 2435-0250900 INTAKE, SW-509	52-7662-615-CAT-1 ROADWAY ITEMS	\$0.00	\$1,476.20	\$0.00	\$1,476.20
#3 - 2554-0114006 WATER MAIN, TRENCHED, POLYVINYL CHLORIDE PIPE (PVC), 6 IN.	52-7662-615-CAT-2 ROADWAY ITEMS - DIVISION 2	\$0.00	\$196.40	\$0.00	\$196.40
#4 - 2554-0114012 WATER MAIN, TRENCHED, POLYVINYL CHLORIDE PIPE (PVC), 12 IN.	52-7662-615-CAT-2 ROADWAY ITEMS - DIVISION 2	\$0.00	\$65,632.81	\$0.00	\$65,632.81
#5 - 2554-0203000 FITTINGS BY WEIGHT, DUCTILE IRON	52-7662-615-CAT-2 ROADWAY ITEMS - DIVISION 2	\$0.00	\$11,029.81	\$0.00	\$11,029.81
#6 - 2554-0204110 WATER SERVICE STUB, COPPER, 1 IN.	52-7662-615-CAT-2 ROADWAY ITEMS - DIVISION 2	\$0.00	\$242.42	\$0.00	\$0.00
#7 - 2554-0204120 WATER SERVICE STUB, COPPER, 2 IN.	52-7662-615-CAT-2 ROADWAY ITEMS - DIVISION 2	\$0.00	\$0.00	\$0.00	\$0.00
#8 - 2554-0207008 VALVE, GATE, DIP, 8 IN.	52-7662-615-CAT-2 ROADWAY ITEMS - DIVISION 2	\$0.00	\$1,579.24	\$0.00	\$1,579.24
#9 - 2554-0207012 VALVE, GATE, DIP, 12 IN.	52-7662-615-CAT-2 ROADWAY ITEMS - DIVISION 2	\$0.00	\$44,985.00	\$0.00	\$44,985.00
#10 - 2554-0210201	52-7662-615-CAT-2 ROADWAY ITEMS - DIVISION 2	\$0.00	\$59,328.60	\$0.00	\$59,328.60
Totals:		\$0.00	\$249,166.08	\$0.00	\$185,452.36

Stockpile	Fund Package	Current Advancements	Advancements To Date	Current Recoveries	Recoveries To Date	
FIRE HYDRANT ASSEMBLY, WM-201						
#11 - 2301-1033090	52-7662-615-CAT-1 ROADWAY ITEMS	\$0.00	\$63,471.30	\$0.00	\$0.00	
STANDARD OR SLIP FORM PORTLAND CEMENT CONCRETE PAVEMENT, CLASS C, CLASS 3 DURABILITY, 9 IN.						
		Totals:	\$0.00	\$249,166.08	\$0.00	\$185,452.36

Summary

Current Approved Work:	\$456,453.50
Current Stockpile Advancement:	\$0.00
Current Stockpile Recovery:	\$0.00
Current Retainage:	\$0.00
Current Retainage Released:	\$0.00
Current Liquidated Damages:	\$0.00
Current Adjustment:	\$0.00
Current Payment:	\$456,453.50
Previous Payment:	\$264,127.64

Approved Work To Date:	\$4,059,546.64
Stockpile Advancement To Date:	\$249,166.08
Stockpile Recovery To Date:	\$185,452.36
Retainage To Date:	\$30,000.00
Retainage Released To Date:	\$0.00
Liquidated Damages To Date:	\$0.00
Adjustments To Date:	\$0.00
Payments To Date:	\$4,093,260.36
Previous Payments To Date:	\$3,636,806.86

Funding Details

52-7662-615-CAT-1 ROADWAY ITEMS:	\$409,279.50
52-7662-615-CAT-2 ROADWAY ITEMS - DIVISION 2:	\$47,174.00
52-7662-615-CAT-3 NON-PARTICIPATING:	\$0.00
Current Payment:	\$456,453.50

52-7662-615-CAT-1 ROADWAY ITEMS To Date:	\$3,449,818.14
52-7662-615-CAT-2 ROADWAY ITEMS - DIVISION 2 To Date:	\$609,728.50
52-7662-615-CAT-3 NON-PARTICIPATING To Date:	\$0.00
Payments To Date:	\$4,059,546.64

Doc Express® Document Signing History

Contract: 52-7662-615 Document: payment-12-20260427

This document is in the process of being signed by all required signatories using the Doc Express® service. Following are the signatures that have occurred so far.

Date	Signed By
04/29/2026	Dakota Simonsen Boomerang Corp. Electronic Signature (Approved by Contractor (Optional))
04/30/2026	James Watters MSA Professional Svs Electronic Signature (Recommended by Engineer)
	(Approved by PIRC (when applicable))



**AGENDA INFORMATION
TIFFIN CITY COUNCIL COMMUNICATION**

DATE:	May 1, 2026
AGENDA ITEM:	Discussion and Consideration of Mayoral Proclamation Request Policy and Council Action as Needed
ACTION:	Motion

Background

The City regularly receives requests for both new and annually recurring proclamations recognizing days, weeks, or months of significance. These requests vary widely in topic and scope, and historically have been evaluated on a case-by-case basis.

As proclamation requests have increased in frequency, the Mayor’s Office and City staff identified the need for a formal policy to:

- Clarify eligibility and content criteria
- Establish a standardized request process and timeline
- Set expectations regarding Council meeting presentations
- Ensure proclamations align with City values and legal considerations

The proposed Mayoral Proclamation Request Policy establishes clear, consistent guidelines for requesting, reviewing, and issuing proclamations in the City of Tiffin. Adoption of this policy will help ensure proclamations reflect local significance, promote positive community values, and are managed efficiently given the volume of requests received.

The proposed policy provides clarity for requestors while preserving the Mayor’s discretion in issuing proclamations. It ensures consistency, transparency, and appropriate use of City resources, while reducing uncertainty regarding eligibility, scheduling, and presentation expectations.

Implementation of this policy is administrative in nature and does not limit the Mayor’s authority; rather, it establishes predictable standards for evaluation and communication.

Staff Recommendation

Staff recommends approval of the **City of Tiffin Mayoral Proclamation Request Policy** as presented.

ATTACHMENTS: Policy



300 Railroad St. PO Box 259 Tiffin, IA 52340
P. 319-545-2572 F. 319-545-4147 www.tiffin-iowa.org

City of Tiffin, Iowa Mayoral Proclamation Request Policy

Purpose

A proclamation is an official announcement issued by the Mayor to recognize a day, week, or month that has significance to the Tiffin community. Proclamations are intended to honor, celebrate, or raise awareness of events, causes, or achievements that positively impact the community.

Eligibility & Criteria

The City receives many requests to present both new and annually recurring proclamations each and every month. As such, formal presentation of proclamations at City Council meetings is limited and the following guidelines have been established by the Mayor's office to ensure all requests can be appropriately considered and reviewed in advance.

To be considered, proclamation requests must meet the following:

- Have local significance to the Tiffin community
- Promote a positive message or community benefit
- Be requested by a Tiffin resident, organization, or group with a local connection
- Recognize a specific date, week, or month

Proclamations will **not** be issued for:

- Political campaigns or election-related matters
- Religious or ideological advocacy
- Commercial or for-profit promotion
- Matters that conflict with City policies or applicable laws

Issuance of a proclamation does not constitute endorsement by the City.

Request Process

To request a proclamation:

1. Submit a written request to the City Clerk's Office.
2. Include a draft proclamation (preferred format includes "Whereas" statements)
3. Provide the following:
 - Name of organization or individual being recognized
 - Requested proclamation date
 - Contact information
 - Name of representative (if attending a Council meeting)
4. Submit requests at least 30 days in advance of the desired date
 - Requests are reviewed by City staff and approved at the Mayor's discretion
 - The City reserves the right to edit submitted language for clarity, format, and appropriateness
 - Proclamations must be requested each year (they are not automatically renewed)

City of Tiffin - Mayoral Proclamation Request Policy

Content Guidelines

Proclamations should:

- Be inclusive and respectful of the community's diversity
- Focus on education, awareness, or recognition
- Avoid controversial or divisive topics
- Reflect values that align with the City's mission and community standards

Presentation at City Council Meetings

Proclamation requests are reviewed by City staff and the Mayor. The City will notify the requestor regarding if and when a proclamation will be issued and whether a presentation at a City Council meeting is available.

If scheduled for presentation, the requesting organization or individual is encouraged to attend the meeting to receive the proclamation from the Mayor. A representative may be invited to offer brief remarks (2–3 minutes).

Guidelines for Receiving a Proclamation at a Council Meeting

- Proclamations are typically presented near the beginning of the meeting. Attendees are encouraged to arrive a few minutes early.
- If you or someone in your group requires accommodations, please notify City staff in advance so arrangements can be made.
- The Mayor may read all or a portion of the proclamation. Representatives will be invited forward to accept it and may bring others with them.
- Representatives should briefly introduce themselves and others present, including names, titles, and organization.
- If invited, representatives may provide brief comments (approximately 2–3 minutes).
- After the presentation, attendees are welcome to remain for the meeting or depart at their convenience.

Additional Information

The City receives numerous requests and cannot guarantee approval or presentation timing. Approved proclamations may be included in City Council agendas, minutes, or other official records

Contact

City Clerk's Office
Abigail Hora, City Clerk
300 Railroad Street
Tiffin, Iowa 52340
ahora@tiffin-iowa.org

City of Tiffin, IA



CLIENT LIAISON:

Andrew Inhelder, PE
Office: 319.364.4773
Cell: 515.802.0906
ainhelder@msa-ps.com

DATE:

May 1, 2026

ON-GOING PROJECTS

REVERSE OSMOSIS WATER TREATMENT PLANT DESIGN – CLINT WIENEN

The precast walls and ceiling for the RO Building have been installed. Rough-Ins for the underground plumbing and electrical are ongoing below the RO Building floor slab. The Contractor is planning to install the roof trusses for the RO Building in the next couple of weeks and pour the floor slab towards the end of the month. The slab and two (2) wall pours have been completed for the clearwell. They are also planning to have the clearwell concrete completed by the end of the month. They will also be pouring the footings and foundation walls for the existing water treatment plant expansion in the next few weeks.

SYSTEMWIDE SANITARY SEWER MODEL – ERIC THOMPSON

MSA is updating the land use data, to reflect known (but not yet completed) development in the City to be the new benchmark for existing conditions. The City is completing drawn down tests on the lift stations. Once completed, MSA will integrate the draw down results into the sanitary model, export outputs, and finalize the model construction.

MSA is creating future growth maps and identifying key infrastructure placement for future development to be discussed with City.

VILLAGE DRIVE & ROBERTS FERRY ROAD SIGNAL DESIGN – CHAD WAGNER

Project is out to bid with bids due on May 14th 2026 at 10AM.

PROJECT UPDATE

HIGHWAY 6 CONCEPT AND COST ESTIMATE – JAMES WATTERS

MSA and City met with IaDOT District 6 to discuss staging on April 22, 2026. Portions of the road will need to be closed for box culvert and road reconstruction with a detour put in a place. A finalized staging layout can be provided to the City for review later in May to better understand detour routes and locations of road closures.

NORTH PARK ROAD IMPROVEMENTS – JAMES WATTERS

The new detour route to Robert's Ferry was put up on March 3rd and North Park Road was closed to traffic on March 9th. Construction resumed later the same week.

The primary work item for the month of April was storm sewer. As of the week of April 30th, water main on the project is complete. Active field tile was found during construction operations and was tied into the storm sewer on Mopar Dr.

Access for homeowners at 300 North Park Road has been established and contact information has been provided to them. Their access will be maintained throughout the remainder of the project and changes will be communicated promptly.

Moving forward, storm sewer work continued the week of March 30th and is 95% complete for the project. Paving is tentatively planned for May or June. Coordination between the North Park Road project and the Homemakers site is ongoing.

A Change Order for a temporary pipe connection to the Homemaker's detention basin has been submitted for Council approval the week of April 30th.

FIRE STATION DRAINAGE IMPROVEMENTS – ANDREW INHELDER

LL Pelling has begun construction. They tied in the western roof drain to the existing drains and paved portions of the driveway and sidewalk. Anticipating completion of concrete the week of 5/4/26.

PROJECT UPDATE

DEVELOPMENT ASSISTANCE – ANDREW INHELDER

NO FURTHER COMMENTS

Development Name	Description	Date of last interaction
Half Moon Ave Road Extension – Temp paving	No further comments.	4/13/26
Park Place City Center, Part 1, Phase 1, Lot 25 – Hotel	No further comments.	4/13/26
Prairie Village Part 3, Phase 4	No further comments	7/11/25
Daytona Estates OPD	No further comments	10/13/23

UNDER CONSTRUCTION

Development Name	Description	Date of last interaction
Park Place City Center, Part 1, Phase 2, Lot 3 – The Boardwalk	Currently under construction. Low point storm pump information to be provided.	4/29/26
Hunt Club Phase 4	Currently under construction.	4/28/26
Homemaker’s Site Plan – Phase 2	Currently under construction.	4/21/26
The States – Anderson Addition OPD	Currently under construction.	4/21/26
Tiffin West	Punchlist walkthrough performed. Contractor to complete punchlist and notify MSA of completion.	4/21/26
Village Drive Extension (By water tower)	Project walkthrough was completed and several punchlist items were identified.	4/29/26
Park Place City Center, Part 1, Phase 4, Lot 1 OPD – Mayfair	Currently under construction.	4/16/26
Clear Creek Village	Currently under construction.	4/23/26
Park Place City Center, Part 2, Phase 6, Lot 33 – Olde Town Building	Currently under construction.	4/16/26
Prairie Village Lot 55 – Medical Clinic	Currently under construction.	4/16/26
Veritas Church Expansion – Phase 2	Currently under construction.	4/21/26
Dollar General	Currently under construction.	4/16/26
Grove Park	Currently under construction.	4/16/26
Tiffin Heights West	Walkthrough performed. Contractor to complete punchlist and notify MSA of completion.	4/21/26
Bailey Way Extension	Currently under construction.	4/21/26
Park Place City Center, Part 4, Phase 4, Lot 22 – Firing Pin	Currently under construction.	4/21/26
301 Main Street Site Plan	Currently under construction.	4/16/26

PROJECT UPDATE

AWAITING RESUBMISSION

Development Name	Description	Date of last interaction
CCA HS & MS Addition	No plans submitted. Drainage report reviewed. Awaiting submission.	4/8/26
Tiffin West – McDonalds	Review comments sent. Awaiting submission.	2/5/26
Park Place City Center, Part 3, Lot 1, EMA Storage Building	Review comments sent. Awaiting resubmission.	2/24/25
Buffalo Ridge Development	Review of concept sent. Awaiting resubmission.	10/29/25

IN REVIEW

Development Name	Description	Date of last interaction
Lotus Hill	In review.	4/28/26
Park Place City Center, Part 1, Phase 6, Lot 6 – Pacific	In review.	4/24/26
Park Place City Center, Part 2, Phase 9, Lot 29 – Movie Theatre	Final Plat in review.	4/1/26
Tiffin West – Phase 1B	Final Plat in review.	3/26/26



Upcoming Infrastructure Project	Description	Next Steps/Schedule
<i>Wastewater Treatment Improvements</i>	<p>The current wastewater treatment facility (WWTF) has a chloride compliance schedule. There is not any wastewater treatment equipment/processes designed to remove chloride so typically source control is the only economical means of meeting compliance. The existing treatment facility is at about 50% capacity. However, if the past growth rate continues an expansion will be required in the next 5-7 years.</p> <p>From design to construction the process typically takes 3-4 years.</p>	<p>Final Compliance with NPDES Permit required October 1, 2025.</p> <p>MSA presented its findings on November 1st, 2022. MSA has prepared a proposed schedule for wastewater treatment, water treatment and water supply improvement projects.</p>
<i>Deer View Ave & Tall Grass Ave & Hwy 6 Intersection Improvements</i>	<p>DOT has agreed to continue the existing permit based on the City's plan to replace the signals with a permanent installation in 2026. Scope includes both pedestrian and vehicle accommodations. MSA is reaching out to the DOT to request a time extension and will begin conceptually reviewing the signals and intersection for DOT approval.</p>	<p>Begin conceptual review of intersection/signals.</p>

**CITY OF TIFFIN
CITY ADMINISTRATOR
REPORT TO THE CITY COUNCIL
May 1, 2026**

- Similar to this time last year, the County Attorney, Treasurer, Auditor and Sheriff are visiting the communities in Johnson County giving a brief update on the activities in their respective offices. This will be at the regular meeting under the ‘Communications and Reports’ portion of the agenda.
- Item I-6 – This agreement is being drafted and reviewed by Legal. It should be included in the packet on Monday.
- Last week we had a preconstruction meeting for the EMA Storage Facility being built at the corner of Bailey Way and Forevergreen Road. The meeting went well. They are currently coordinating the utility work but plan to start the project within the next couple of weeks.
- LL Pelling has completed the regrading and repaving of the parking lot on the north side of the fire department. The work looks good. MSA will review the completed project prior to final acceptance.
- Brian Shay will review with the City Council Chapter 52 of the City Code, Weeds and Noxious Growths, during his report on Tuesday night.
- With no additional comments on the draft of the Mayoral Proclamation policy, this item is on the regular agenda for formal consideration and approval.
- May 17th – May 20th, Council Person Schnedler and I will be at the ICSC Economic Development Conference. We will remote into the next council meeting on Tuesday, May 19th.
- Just a friendly reminder the City-Wide Clean-up is scheduled for Saturday, May 9th. We believe we have everything ready to go as this year’s process will mirror last year’s drop-off only process. This process went really well last year so there does not seem to be a need to further change it. Both local haulers who can provide the pick-up service for those who can’t bring their material to the drop-off site are on board again this year and are willing to provide that service for the same cost (\$25.00) as the City has provided in the past clean-ups.

EXHIBIT A
City of Tiffin, Iowa
Nuisance Mowing Enforcement Procedure
Ordinance No. 2022-493

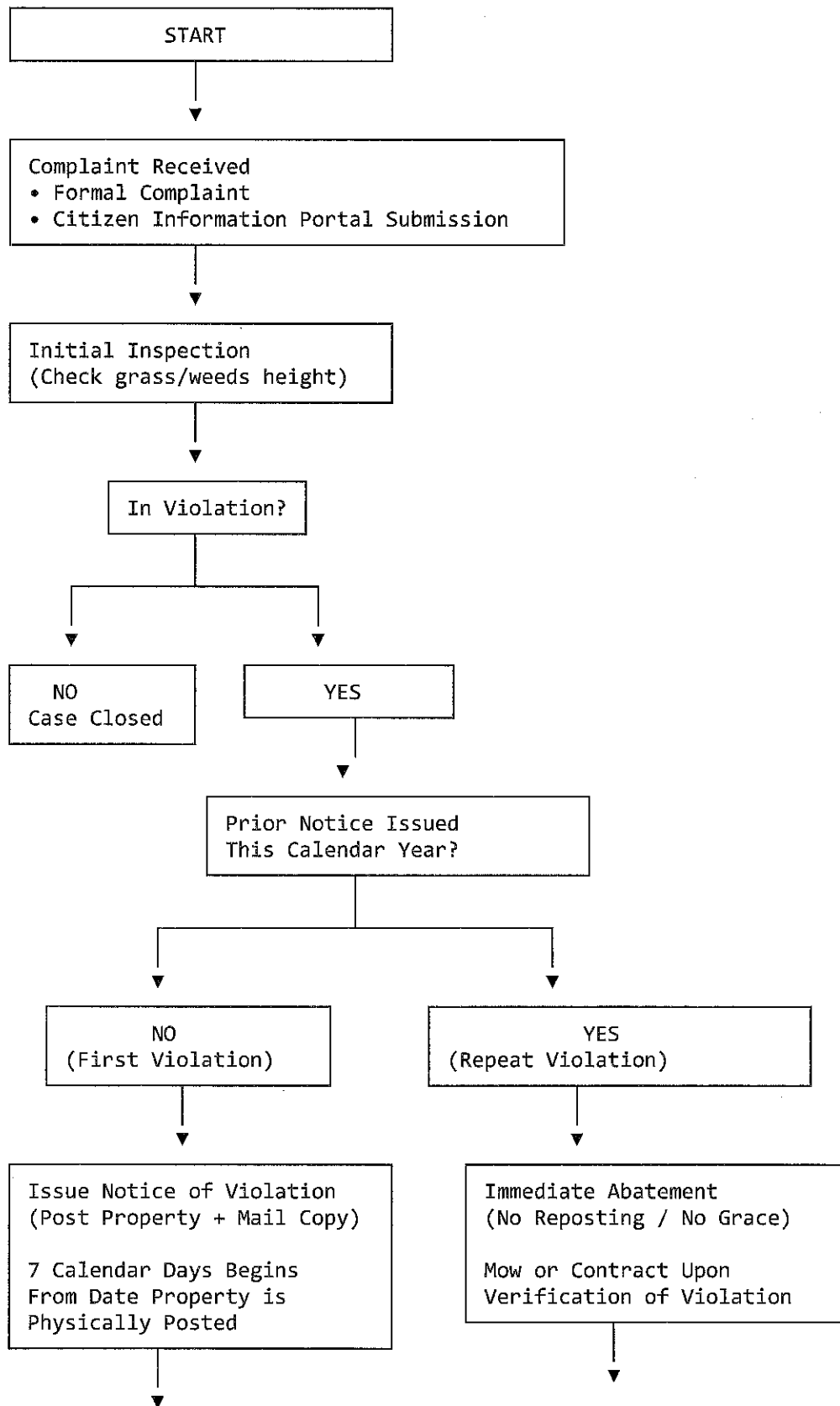

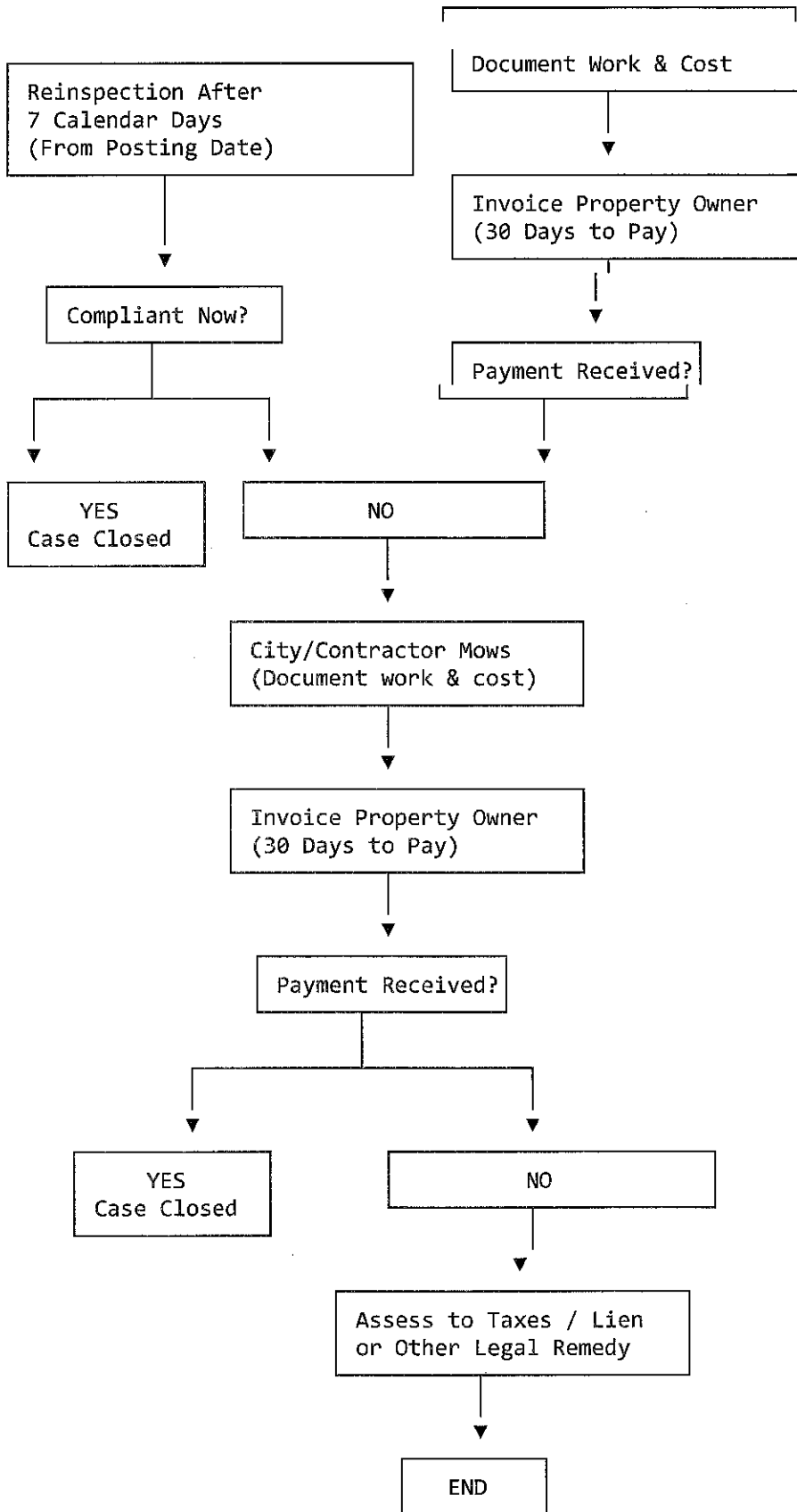

Adopted: _____

Effective Date: _____